

# ROREX

## General Presentation Catalogue



*DN 4000*

*50 m<sup>3</sup>/s*

## **ROREX PIPE SRL**

33 Aviației Street, Buftea City,  
Ilfov County, Romania  
Tel. no.: +40 723 277 877  
Fax: +40 376 206 509  
office@rorexpipeline.com  
www.rorexpipeline.com

# ROREX PIPE

**GENERAL PRESENTATION CATALOGUE**

**GRP PIPE SYSTEMS**



## Table of Contents

<b>A. The Administration of Water in Dacia</b>	<b>3</b>
<b>B. Company Profile</b>	<b>5</b>
<b>C. GRP</b>	<b>7</b>
<b>C1. GRP Composites</b>	<b>7</b>
<b>C2. GRP Pipes Applications</b>	<b>8</b>
<b>1. The Properties and Advantages of the Product</b>	<b>10</b>
<b>1.1. Why GRP Pipes?</b>	<b>10</b>
<b>1.2. Why ROREX Pipes?</b>	<b>11</b>
<b>2. Performance Standards</b>	<b>14</b>
<b>3. Raw Materials</b>	<b>16</b>
<b>3.1. Description</b>	<b>16</b>
<b>3.2. Quality Control</b>	<b>17</b>
<b>4. Production Process</b>	<b>19</b>
<b>5. The Finite Pipe Structure</b>	<b>22</b>
<b>6. Pipe Range</b>	<b>23</b>
<b>7. Pipe Properties</b>	<b>26</b>
<b>8. Quality Control for Finished Pipes</b>	<b>34</b>
<b>9. Considerations on Design and Proper Operation</b>	<b>36</b>
<b>10. Pipes for Special Applications</b>	<b>42</b>
<b>10.1 Biaxial Pipes</b>	<b>42</b>
<b>10.2 No-sand Pipes</b>	<b>44</b>
<b>10.3 Jacking Pipes</b>	<b>46</b>
<b>10.4 Relining</b>	<b>48</b>
<b>11. Pipe Joining Elements</b>	<b>48</b>
<b>11.1 Unrestrained Pipe Joining Elements</b>	<b>49</b>
<b>11.1.1 Reka Couplings</b>	<b>49</b>
<b>11.1.2 Mechanical Steel Couplings</b>	<b>51</b>
<b>11.2 Restricted Pipe Joining Elements</b>	<b>52</b>
<b>11.2.1 Laminated Joints</b>	<b>52</b>
<b>11.2.2 Flanges</b>	<b>52</b>
<b>11.2.3 Glued Couplings (COMBI)</b>	<b>53</b>
<b>12. Fittings</b>	<b>53</b>
<b>13. GRP Pipe Installation</b>	<b>55</b>
<b>13.1 Choosing the Pipe Characteristics According to the Conditions in the Field</b>	<b>55</b>
<b>13.2 Trench Details</b>	<b>57</b>
<b>13.3 Installation Types</b>	<b>59</b>
<b>13.4 Special Considerations</b>	<b>60</b>
<b>13.5 Installed Pipes Deflection</b>	<b>60</b>
<b>13.6 Joint Angular Deflection</b>	<b>60</b>
<b>14. Special GRP Products</b>	<b>62</b>

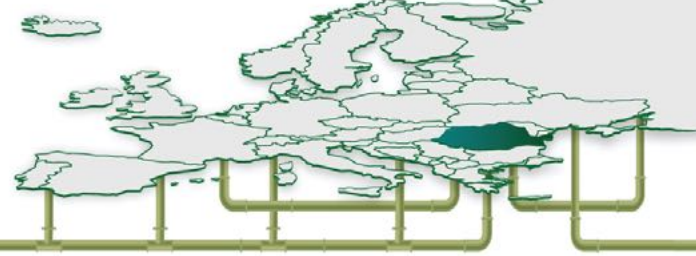

## A. The Administration of Water in Dacia

From the beginning of times, water was the essential element which influenced the migration and settlement of people. On the territory of modern Romania, where Dacia once was, complex water capturing and distribution methods are known, starting with the period of antiquity, under the form of aqueducts. After the roman emperor Traian conquered Dacia (106 A.D.), the romans built big cities, with defense enclosures, forums, amphitheatres, thermae and aqueducts. Remains of the latter were found not only in the capital city Ulpia Traiana Sarmizegetusa, but also in smaller cities, rising in the degree of complexity compared to the preceding historical periods. The ancient Roman architect and engineer Vitruvius writes about the science of aqueducts, marking how important it was to first establish a source of water with superior quality. This was ascertained through the types of rocks and soil it came from and then checked according to criteria such as taste, limpidity, smell, physical aspect<sup>1</sup>.

The roman aqueduct was an artificial river, whose slope was meticulously calculated so as to flow, aided by gravity, up to a collection point - castellum - situated at a higher altitude than the city. From there, the water was transported through different types of pipes to a distribution basin at the edge of the city, and from there it was distributed to the interior of the city through another pipe network. The water could be directed towards aqueducts by constructing a groove with stone or brickwork walls, or by using ceramic (Fig.1, pg. 4) or lead pipes (Fig.2, pg. 4) depending on the type of slope. The majority of the aqueduct length was represented by the brickworks channels, that followed the geometry of the terrain, having different shapes and dimensions. The ceramic pipes generally had a diameter of 20 - 25 cm, and a length of 40 - 60 cm and were connected to each other through couplings shaped like sockets which were present at one of the ends. The socket was introduced in another pipe with a widened end (Fig. 1, pg. 4). The lead pipes (2.0 - 3.6 cm thickness and 10 feet length<sup>2</sup>) were cast on a marble slab, and the resulting plates were bent around a wooden shape and welded together with an alloy named *tin* (Fig. 3, pg. 4). These were used for siphons, because they could handle the high pressure, as well as for the water distribution network inside the city, taking water to private households and to public fountains.<sup>3,4</sup>

Thus, building on the knowledge of our ancestors, we are proud to carry the science of water distribution forward, through continuous research and development. We develop and manufacture high-performing GRP pipes, based on a steadfast process, and designed to withstand for many generations.

**This is where Rorex's slogan "Success through quality" comes from.**

1 Vitruvius IV

2 Vitruvius VI

3 *Istoria alimentării cu apă în Municipiul Turda*, www.caaries.ro

4 *Despre aprovizionarea cu apă potabilă a cetății Callatis în epoca romană*, Gh. Papuc  
Photos Fig. 1,2,3 pg 4 *Tehnici de aprovizionare/distribuție cu apă în Dacia Romană*, G. Băeșan

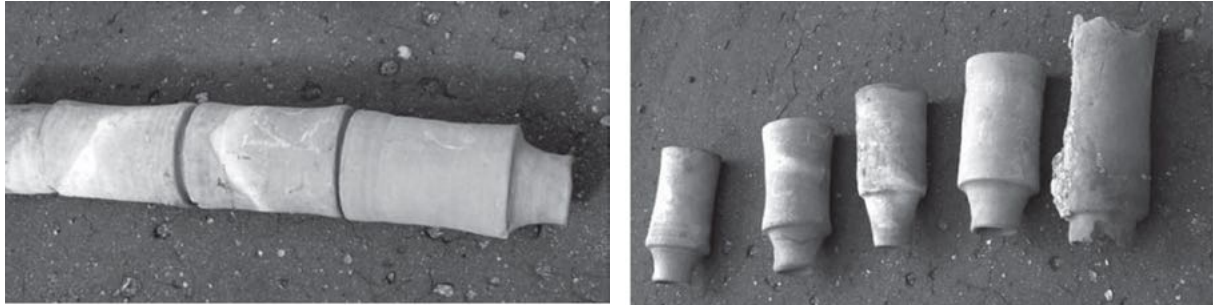
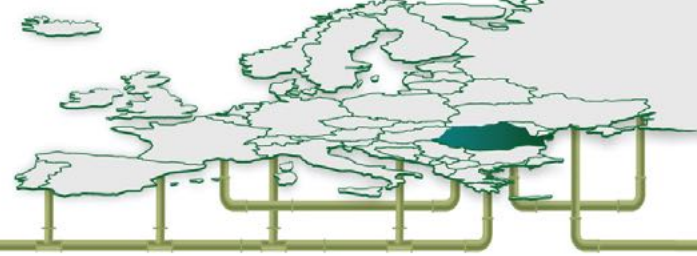

Fig. 1 Ceramic pipes from Sarmizegetusa (photo G. Băeșan)



Fig. 2 a) Lead Pipes, b) Separately cast fittings - Sarmizegetusa (photo Piso, G. Băeșan 2000)

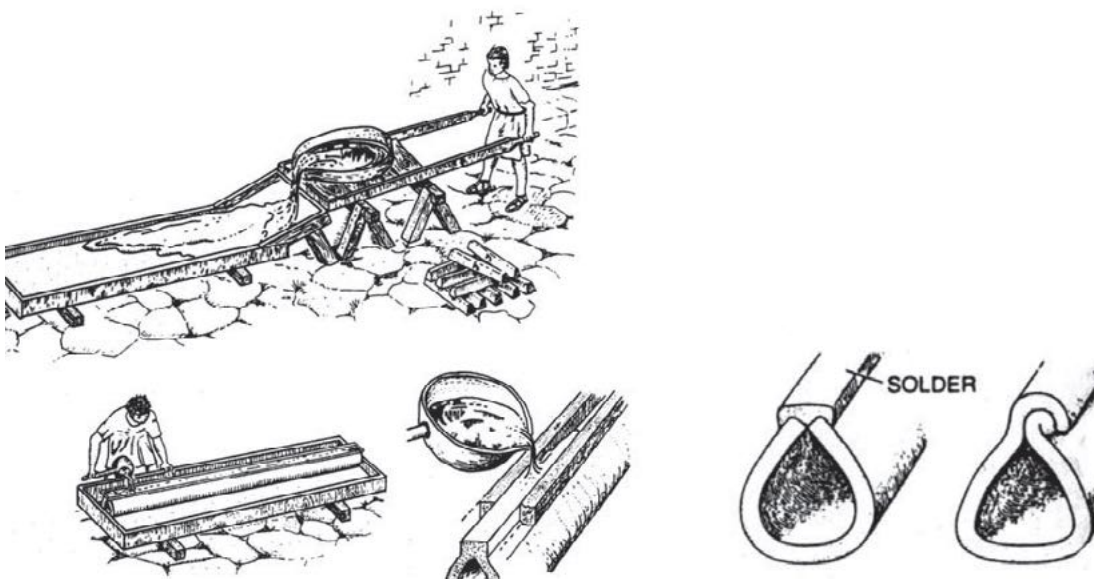
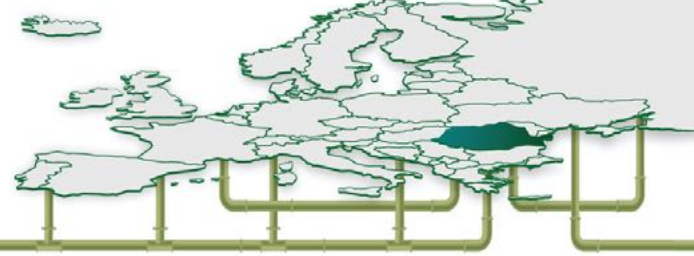

Fig. 3 Lead pipe Manufacturing process in the Roman Era (Roman Aqueducts and Water Supply, T. Hodge 1995)



## B. Company Profile

ROREX occupies a total area of 36,200 m<sup>2</sup>, with a built surface of 4,250 m<sup>2</sup>. The factory and offices are located in Buftea city, Ilfov county.



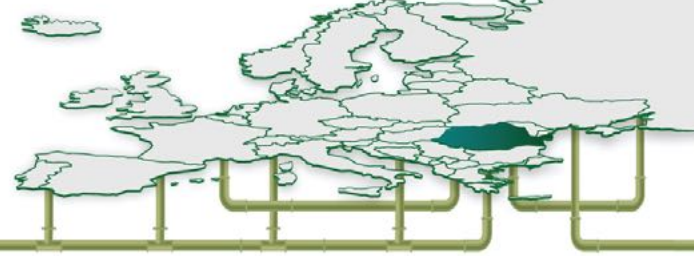

ROREX cooperates with Faratec for the pipe and technology system, having sales and collaborations on both the national and international markets.

Faratec was created in the year 1992 and has a vast experience in GRP pipes, as well as in the composite sector. The manufactured pipes encompass all the categories of transported water, categories for special process applications and for the transport of petrochemicals. R&D studies and the high-performing technology developed by the Faratec Technology Center have allowed Faratec to meet orders of over 10,000 km of pipes all-around the world - Europe, MENA region, CIS region and Asia.

ROREX products meet all local and international standards such as: CEN, ISO, AWWA, ASTM, BSI. For the pressure and stiffness classes mentioned in Fig. 4, all the products are guaranteed by ROREX.

This range represents the standard production. For non-standard applications and special products, please contact ROREX Marketing Department.

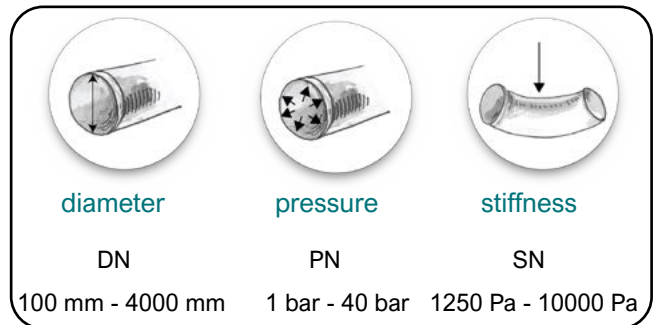
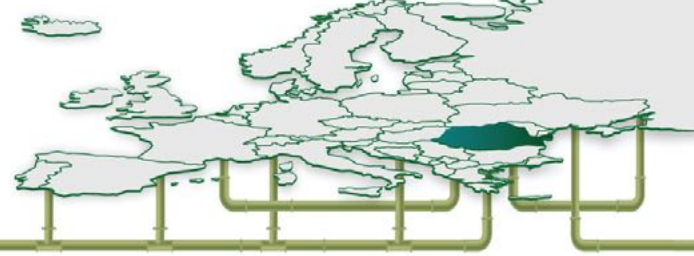

Fig. 4 The range of pipes produced by ROREX - possible diameter, pressure and stiffness classes







## C. GRP

### C1. GRP Composites

The material called GRP (glass fiber reinforced polyester) is a composite material which contains a matrix of thermosetting resin (epoxy, unsaturated polyesters, vinyl ester or bisphenol) to which glass fibers are added, and for certain applications, quartz sand (min. 98% silica dioxide) is added as well. Depending on the application and the manufacturing process, the glass fibers can be randomly arranged, flattened in a mat, or woven.

GRP is more flexible than carbon fiber, having a higher breaking point, and as such, a higher strength-to-weight ratio. From an electro-magnetic characteristics stand point, it is a insulating, non-magnetic and radiotransparent material. It is chemically inert in many circumstances and can be molded in complex shapes, and thus can have numerous different aspects (Fig. 5).



GRP roof tiles



GRP ships

Fig. 5 Different objects made from GRP



GRP wind blades



GRP chopper blades

As such, GRP is used in multiple fields such as: the automobile and aeronautic industry (structural elements, floors etc.), the chemical industry (pipes), the energy industry (wind turbines etc.), sports products (surf boards, helmets, tennis rackets etc.), electrical and electronic products, constructions (as an insulating material, domes, roof tiles etc.)

In the year 2017, the GRP market was estimated at 17.1 billion USD. The production costs for this type of material are relatively low, the production process is environmentally friendly and the life span is 50 - 100 years, thus making it a sustainable product, whose market share is in continual growth.

## C2. GRP Pipes Applications

potable water treatment plants



mining

potable water mains and distribution networks



steam power plants



chemical products factories

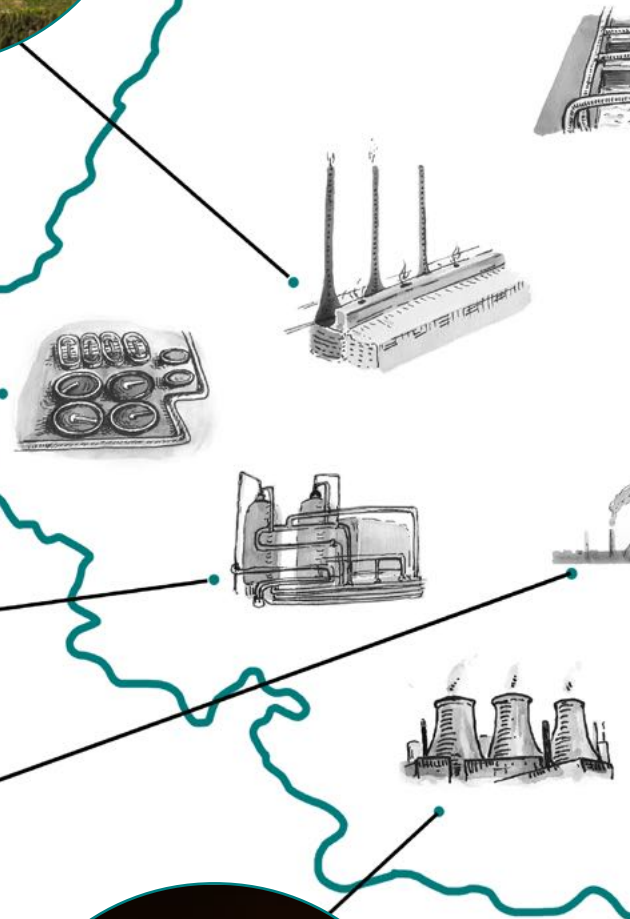

Within a country, the GRP pipes (glass fiber reinforced polyester and sand insertion) have a wide variety of uses. Fig. 6 presents a few of the main fields where they can be used.

Fig. 6 GRP pipe fields of use

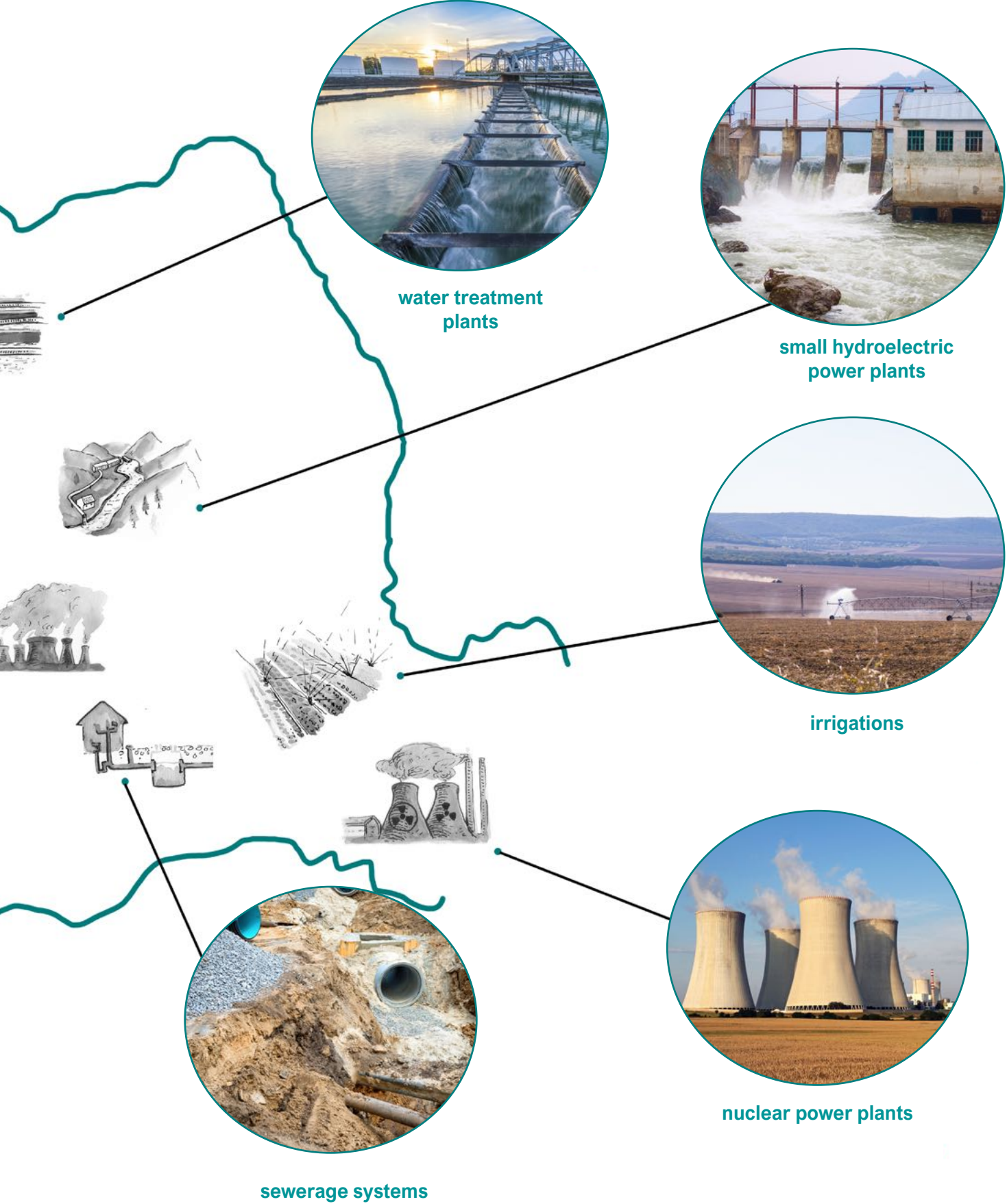

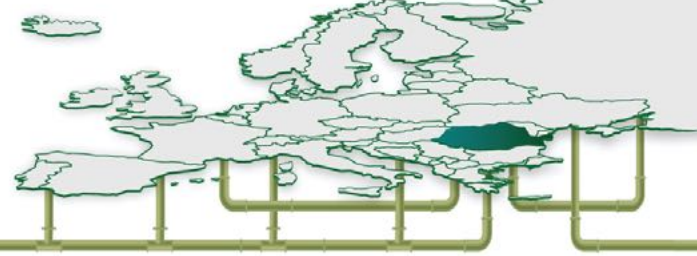

## 1. The Properties and Advantages of the Product

### 1.1. Why GRP Pipes?

The production of GRP pipes has at its core the principle of **sustainable development**. Thus, throughout the entire length of the technological flow, from raw materials to the final product, the carbon footprint is low, and the pipes are made to keep for many generations. From an economic sustainability stand point, their production costs are relatively low, and their physical and mechanical properties, such as low weight, abrasion resistance and smooth internal surface, decrease the transport, handling and maintenance costs.

The main issue with the installed pipes in time is **corrosion**.

In the year 2017, the corrosion cost was estimated at 2.5 trillion USD - 3.4% of the global GDP. This can occur from various reasons, the most common being: the low or high pH of the water flowing through the pipe or of the soil the pipe's exterior comes into contact with, a high level of dissolved oxygen, the existence of swampy or salty terrains, or the existence of dispersion currents (stray currents).

Corrosion causes 3 distinct problems:

- » the pipe loses from its mass gradually;
- » deposits made of the resulting compounds from the degradation of the pipe can accumulate, which leads to head loss;
- » a decrease in water quality (for example, the occurrence of 'red water' in the case of iron containing pipes, or the increase in pH in the case of concrete pipes).

GRP pipes offer a net superiority compared to any other materials used today when it comes to corrosion.

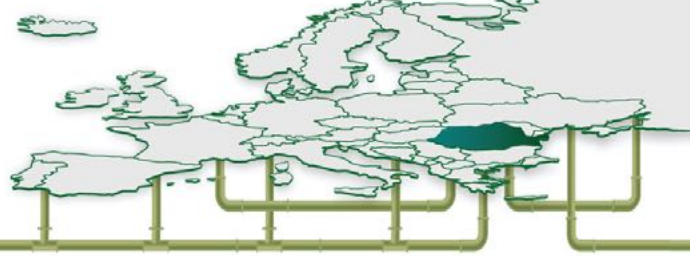

## 1.2. Why ROREX Pipes?

### Environmentally Friendly



» they are based on raw materials which have a low impact on the environment: **glass fibers** are mostly made of borosilicate glass, which is melted and extruded into fibers, **resin** is a byproduct from the petroleum production process, **sand** is made of fine silica granules;

» neither the raw materials production process, nor the one corresponding to the finite products emit toxic byproducts;  
» they have a low carbon footprint - the pipe production process uses a relatively low amount of energy;  
» they need a lower amount of pumping energy due to the smooth internal surface which reduces losses due to friction.

### Sustainable



» long service life: > 50 years ;  
» low transport and manipulation costs because they have a low weight: for the same performance they are 75% lighter than ductile iron pipes and 90% lighter than concrete pipes;

» reduced exploitation and maintenance costs with the same superior chemical and hydraulic characteristics.

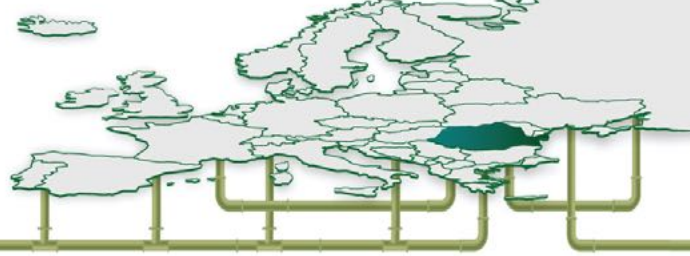

### Superior Hydraulic Characteristics



- » very smooth inner surface - low friction losses;
- » high abrasion resistance;
- » low wave celerity - reduces surge and water hammer pressures;
- » the GRP pipes can take an over-pressure 40% higher than the working pressure and the hammer pressure is up to 50% less than ductile iron or steel.

### Desirable Physical and Chemical Properties



- » corrosion resistance on a high pH range;
- » they don't require linings, wraps or cathodic protection;
- » they have a long and efficient service life;
- » the hydraulic characteristics stay constant on a long term;
- » high flexibility - they allow an elastic deformation with up to 25% of the diameter;
- » keeping the resistance structure intact;
- » small expansion coefficient and UV resistance; they are good for above-ground installation.

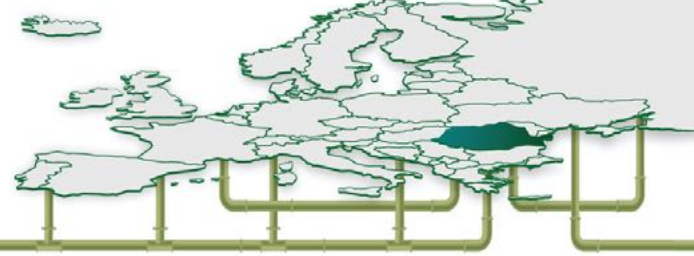

### Long Standard Lengths

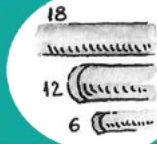

- » standard lengths of 6 m or 12 m, but one can manufacture custom pipes up to 18 m;
- » the risk of external damage is minimized;
- » short installation time because the number of couplings is reduced.

### Customized Pipe Coupling Methods



- » watertight couplings with elastomeric gaskets for buried applications and adhesive bonded or laminated couplings for above-ground applications;
- » short installation time due to the ease of joining;
- » accommodation to small directional changes without fittings or differential settlements.

### Advanced Technology Pipe Design



- » production of pipes in accordance with local and international standards like ASTM, AWWA, BSI, DIN, CEN etc.
- » high stability of products on a worldwide scale, ensured by a high-performance and trustworthy production;
- » flexible manufacturing process;
- » custom diameters can be manufactured for special projects like relining projects.

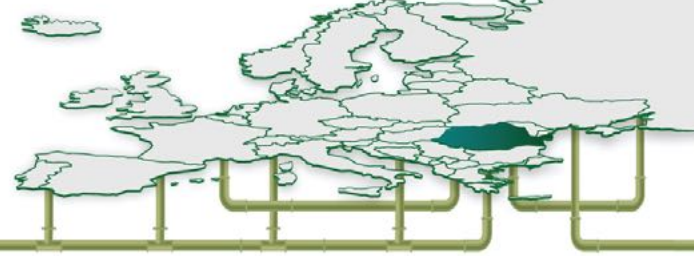

## 2. Performance Standards

Performance standards are documents, established and approved by consensus by a recognized body, aimed at developing rules, guidelines or characteristics for activities or their results, in order to improve public health practices. They are experience-based and regularly updated, so they will always reflect the performance needed to meet real market conditions.

ROREX pipes are designed to meet multiple international performance standards: EN (developed by the European Commission for Standardization), ISO (developed by the International Organization for Standardization), ASTM (developed by the American Society for Materials Testing), AWWA (developed by the American Association for Hydrotechnical Works), ASME (American Association of Mechanical Engineers).

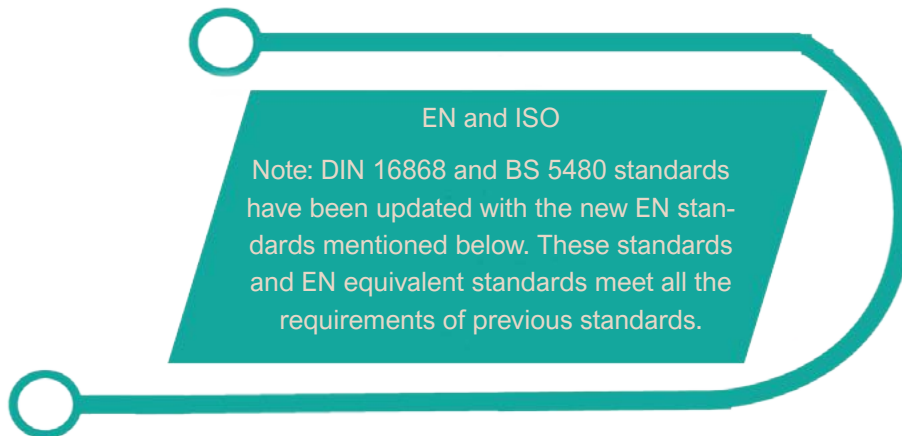

<b>EN 1796</b>	Plastics piping systems for water supply with or without pressure - Glass-reinforced thermosetting plastics (GRP) based on unsaturated polyester resin (UP)
<b>EN 14364</b>	Plastics piping systems for drainage and sewerage with or without pressure - Glass-reinforced thermosetting plastics (GRP) based on unsaturated polyester resin (UP) - Specifications for pipes, fittings and joints.
<b>ISO 10639</b>	Plastics piping systems for pressure and non-pressure water supply - Glass-reinforced thermosetting plastics (GRP) systems based on unsaturated polyester (UP) resin
<b>ISO 10467</b>	Plastics piping systems for pressure and non-pressure drainage and sewerage - Glass-reinforced thermosetting plastics (GRP) systems based on unsaturated polyester (UP) resin

In the year 2021, these standards were unified in the standard EN ISO 23856:2021.



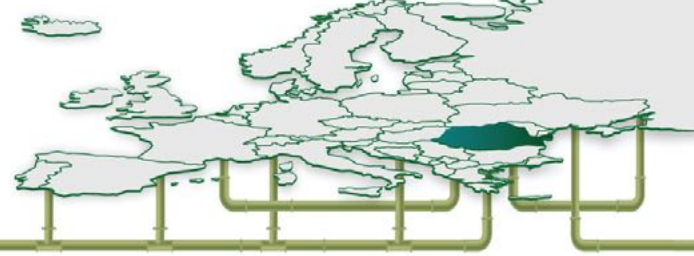

**ATSM**  
These standards include performance requirements for the quality control tests

<b>ASTM D 3262</b>	Standard Specification for "Fiberglass" (Glass-Fiber-Reinforced Thermosetting-Resin) Sewer Pipe
<b>ASTM D 3517</b>	Standard Specification for "Fiberglass" (Glass-Fiber-Reinforced Thermosetting-Resin) Pressure Pipe
<b>ASTM D 3754</b>	Standard Specification for "Fiberglass" (Glass-Fiber-Reinforced Thermosetting-Resin) Sewer and Industrial Pressure Pipe

**AWWA and ASME**  
AWWA has the only design manual AWWA M45 which contains many chapters concerning GRP pipe design, for both underground and overground applications.

<b>ANSI/AWWA C950</b>	<b>Fiberglass pressure pipes</b> This is one of the most comprehensive product standards in existence for GRP pipes. This standard for pressure water applications has extensive requirements for pipes and joints, concentrating on quality control and prototype qualification testing.
<b>ASME B31</b>	Pressure piping
<b>ASME B31.3</b>	Process piping
<b>ASME B16.5</b>	Pipe Flanges and Flanged Fittings

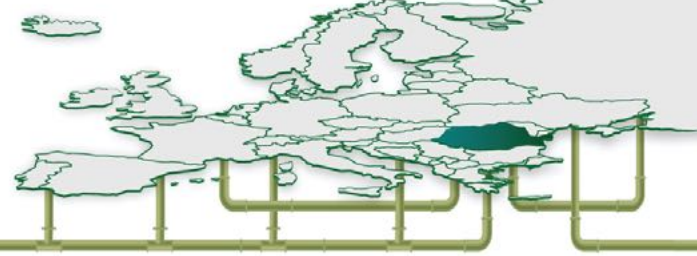

### 3. Raw Materials

#### 3.1. Description

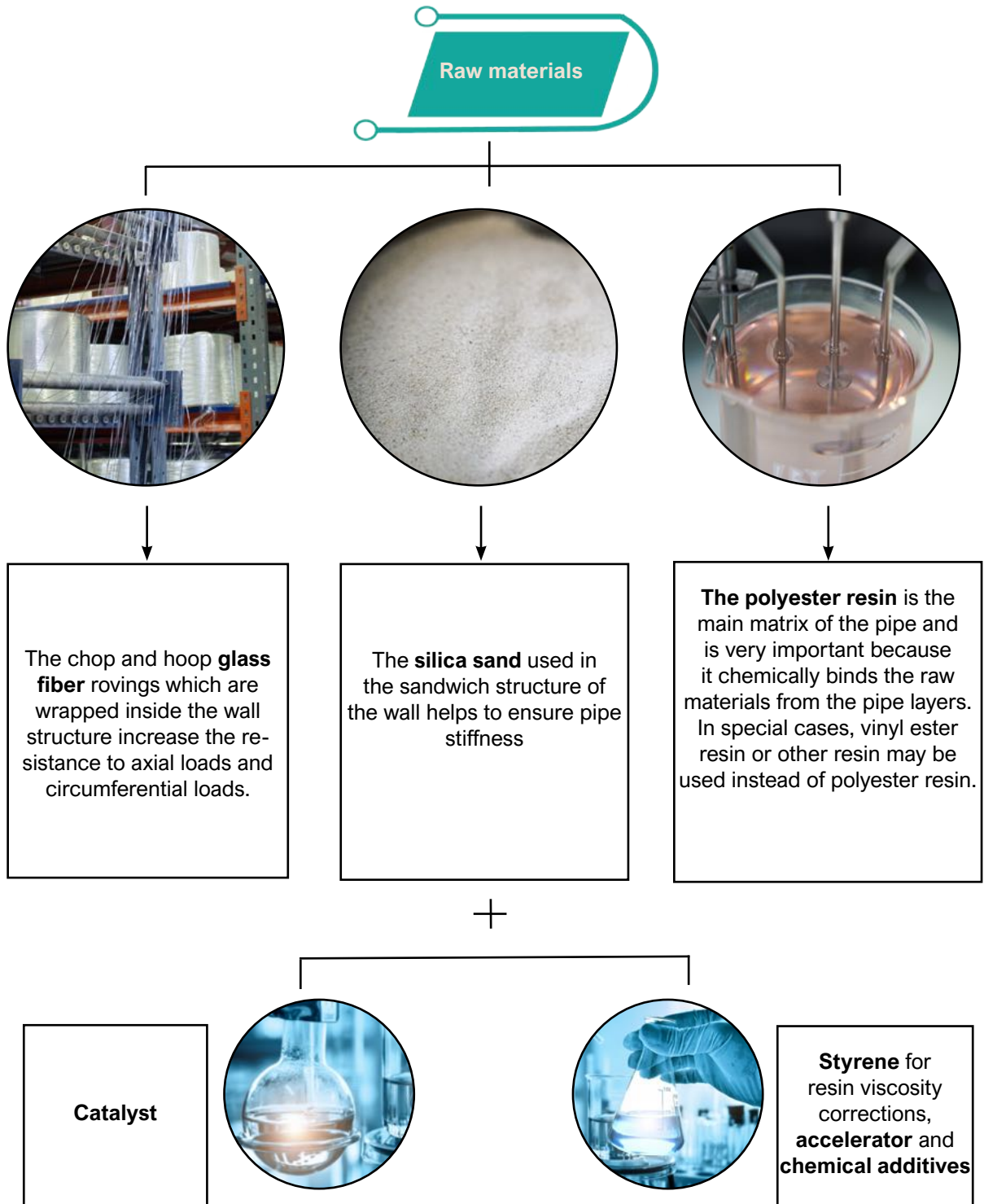

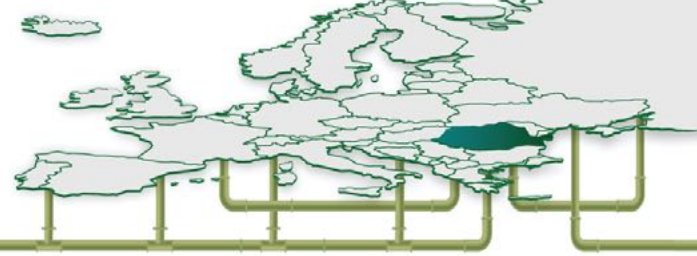

### 3.2. Quality Control

All raw materials are purchased with supplier quality certificates, and each batch is inspected and tested in our laboratories before entering the production process, using specific tests for each type of raw material:



- » Determination of resin solids content
- » Determination of volumetric contraction of the resin at curing
- » Determination of resin acidity index
- » Determination of dynamic viscosity
- » Determination of kinematic viscosity
- » Fire testing
- » Determination of bending resistance
- » Determination of reactivity
- » Determination of tensile strength - cured resin
- » Determination of gel time



- » Determination of sand carbonate content
- » Determination of sand water absorption capacity
- » Determination of sand humidity
- » Determination of particles distribution
- » Establishing the loss of ignition



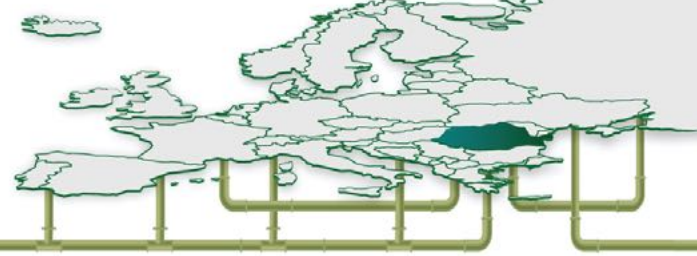

**Glass fiber**

- » Determining glass fiber loss of ignition
- » Determining glass fiber water absorption capacity
- » Determining the number of fibers from the weave
- » Determining the humidity of the glass fiber products
- » Determining the weight per unit surface of glass fiber products
- » Determination of TEX
- » Determining glass fiber traction properties
- » Determining the fuzzing and smoothness of the rovings



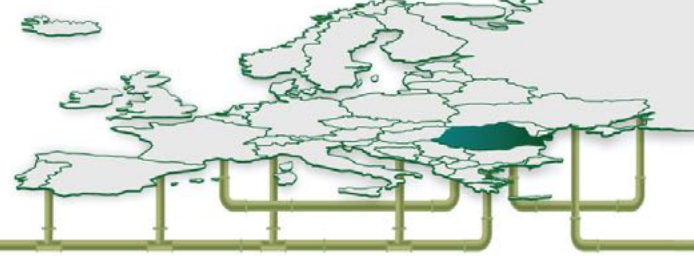

## 4. Production Process

Fig. 7 ROREX GRP pipe production process diagram

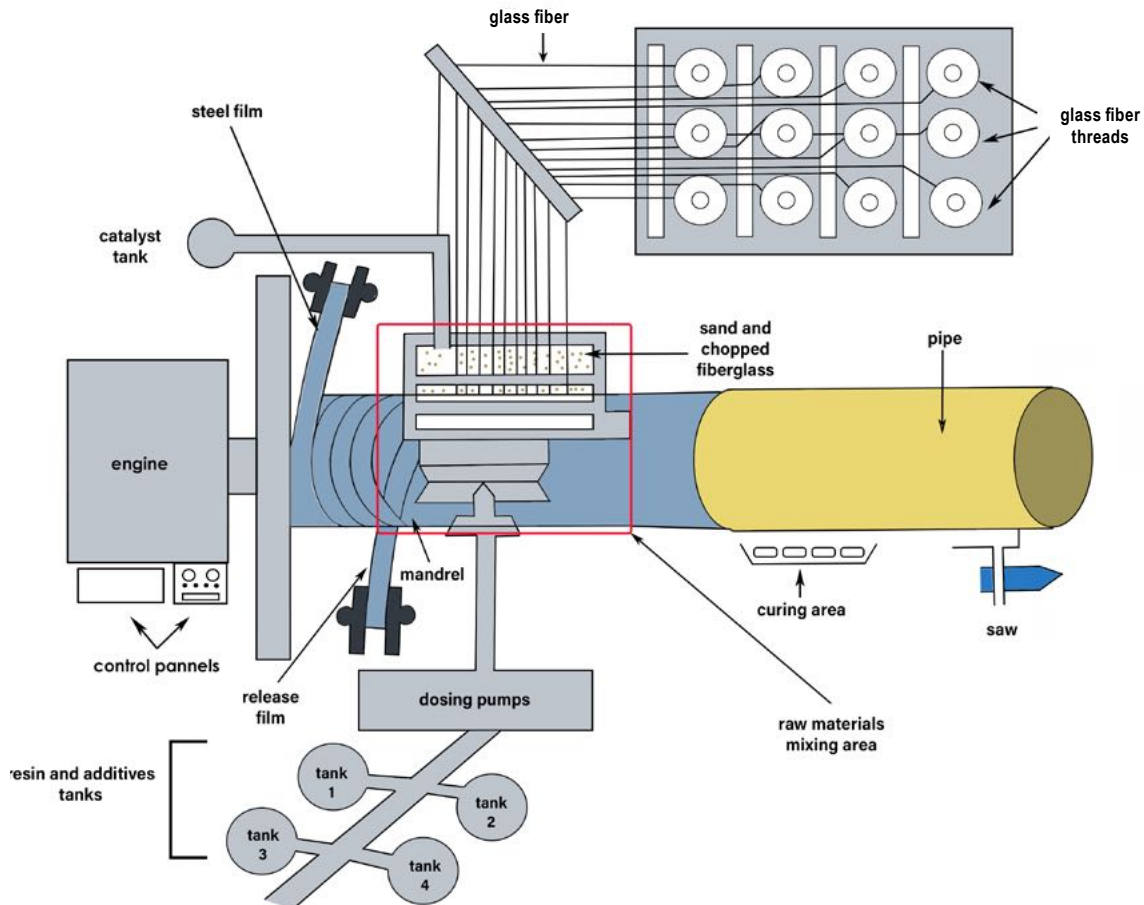

ROREX pipes are produced using the continuous advancing mandrel, which is state-of-the-art in GRP pipe production today. This process produces a range of diameters, from 100 mm to 4000 mm.

The production process consists applying raw materials, in a certain order and in certain quantities, on the exterior surface of a steel mandrel which continuously advances (Fig. 7). In order to protect the mandrel and to be able to detach the final product from it, at the beginning, a release film is applied, which is subsequently removed from the interior of the pipe at the end of the process.

The basic principle of the continuous advancing mandrel process implies using glass fiber reinforcements in the circumferential direction of the pipe, as well as chopped rovings, which reinforce the axial direction of the pipe. These two types of reinforcements ensure the resistance of GRP pipes to both internal loads (pressure) and external loads.

Once all the raw materials have been applied, the resin curing process begins. It is

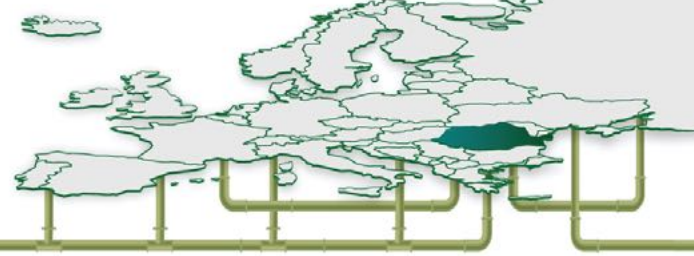

carried out under the influence of heating, both the mandrel, using an induction system, and the exterior layer of the pipe, using an infrared radiation system.

After the resin is cured, the pipes are cut to the desired size.





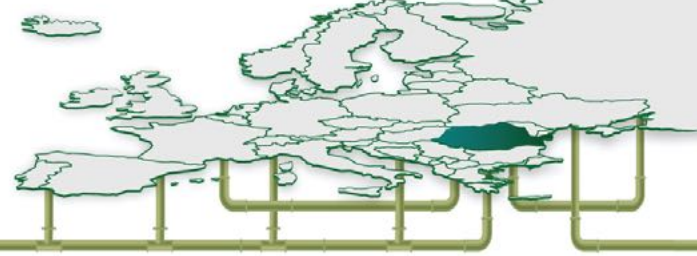

## 5. The Finite Pipe Structure

ROREX GRP pipes have a sandwich-type structure, made out of five layers: the interior liner, the inner structural layer, the core, the outer structural layer and the exterior liner. The thickness, as well as the proportion of different raw materials can differ in accordance to the type of pipe produced. For example, the uniaxial pipes have a higher degree of glass fiber reinforcement on the circumferential direction, the biaxial ones are also reinforced on the axial direction, and the jacking pipes have a much higher wall thickness (especially in the core layer) compared with the previous two types of pipes. Fig. 8 presents the general internal structure of a pipe.

**The interior liner** is the layer which comes in direct contact with the transported fluid. It has a very high resin content, reinforced with a very fine type C glass fiber mat - which constitutes a chemical resistance barrier - and with chopped glass fiber. The interior liner is designed to ensure a minimal friction coefficient and a maximum resistance to corrosion and abrasion. The type of resin can differ depending on the fluid being transported through the pipe.

**The inner and outer structural layers** are comprised of reinforced resin with a high content of winding fiber glass and chopped fiber glass. These ensure the structural integrity of the pipe as well as the tensile strength, on both the circumferential and the axial directions.

**The core** is comprised of resin reinforced with a small amount of chopped fiberglass content and silica sand. This layer contributes to ensuring the stiffness class of the pipe in an essential way, and thus takes over a large part of the external mechanical loads, which appear during the operation period, as well as during transport and installation.

**The exterior liner** is a thin layer, with a high resin content reinforced with type C fiber glass mat. This gives a smooth aspect and an increased resistance to corrosive agents from the environment. The type of resin and/or the additives that are used can differ based on the environment in which the pipe is installed.

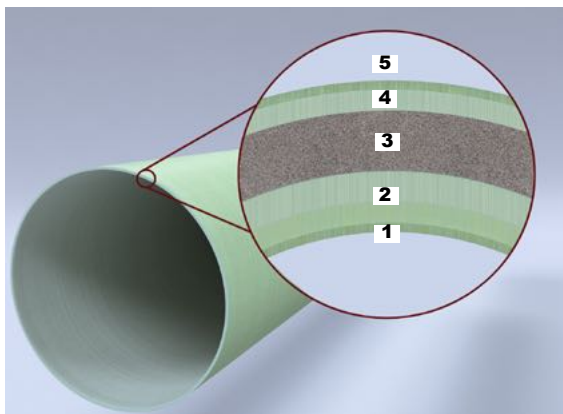

*Fig. 8 The internal structure of ROREX standard GRP pipes, where:*

- 1 - interior liner
- 2 - inner structural layer
- 3 - core
- 4 - exterior structural layer
- 5 - exterior liner



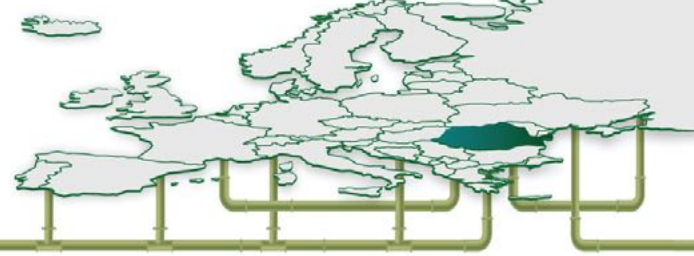

## 6. Pipe Range

Depending of the axial force to which they will be subjected and/or the installation means, ROREX can produce four types of pipes: uniaxial, biaxial, no-sand pipes and jacking pipes.

**Uniaxial (standard) pipes:** the most common pipes, designed for underground installations, where they are supported by the adjacent soil and the backfill material. In this type of pipe, the action of axial forces due to directional changes is taken over by thrust blocks.

**Biaxial pipes:** Designed for above-ground applications, as well as underground ones, in conditions where the soil is weak and offers very little support. In this type of pipe, the axial forces due to directional changes are taken over by the pipe and its couplings. More details on biaxial pipes and their installation can be found in chapter [10. Pipes for special applications, 10.1 Biaxial pipes \(pg. 42\)](#).

**No-sand pipes:** have physical, mechanical and chemical properties which are superior to the pipes that contain sand and are used in special applications or when the operating pressure is very high. More details about no-sand pipes can be found in chapter [10. Pipes for special applications, 10.2 No-sand pipes \(pg. 44\)](#)

**Jacking pipes:** designed for trenchless applications and installed through the pipe jacking method, which involves pushing the pipes into the soil using a hydraulic jack. The pipes are placed behind a shield which digs all the way through the entire route. More information on jacking pipes and their installation can be found in chapter [10. Pipes for special applications, 10.3 Jacking Pipes \(pg. 46\)](#).

The following details as well as the information presented in chapters 7-9 mainly refer to uniaxial pipes.

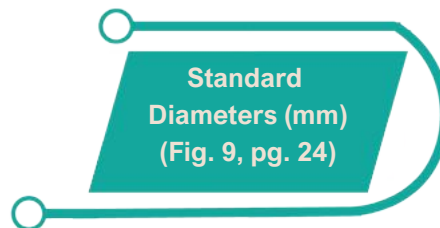

<b>Multiple mandrel system</b>	100	150	200	250	300				
	300	350	400	450	500	600	700	800	900
<b>Continuous advance process</b>	1000	1100	1200	1400	1600	1800	2000	2200	2400
	2600	2800	3000	3200	3400	3600	3800	4000	

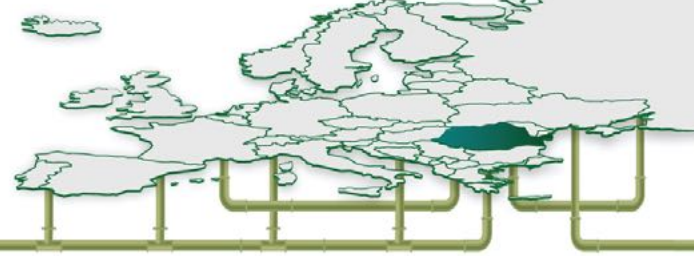

Fig. 9  
ROREX GRP pipes of  
different diameters

**Standard Lengths (m)**

<b>diameters</b>	12	<b>diameters</b>	6
<b>≥ 300 mm</b>		<b>&lt; 300 mm</b>	

On demand, ROREX can produce pipes in the range of lengths 0.3 m - 15 m for diameters larger than 300 mm. On demand, other intermediate diameters between 100 mm - 4000 mm can also be produced.

**Pressure Classes**

<b>Pressure class (bar)</b>	32	25	20	16	15	12	10	9	6
<b>Diameter upper limit (mm)</b>	1600	1600	1600	4000	4000	4000	4000	4000	4000

The classification of the pipes in pressure classes was made according to the specifications from the *AWWA M45 Fiberglass Pipe Design Manual*. The evaluation of the pipes in pressure classes was done on the full operating pressure and at the maximum recommended burial depth. Other pressure classes can be provided on demand.

**Stiffness Classes**

Reference	Unit of measurement	Stiffness class (SN)			
ISO	Pa	1250	2500	5000	10000
AWWA	kPa	62	124	248	496

GRP is a flexible material which, in combination with the behavior of the soil around the pipe, allows a good take over of external loads. Unlike rigid pipes, which break under the action of high loads, the flexible GRP pipes have a high resistance and allow the deformation and redistribution of loads to the soil around them.

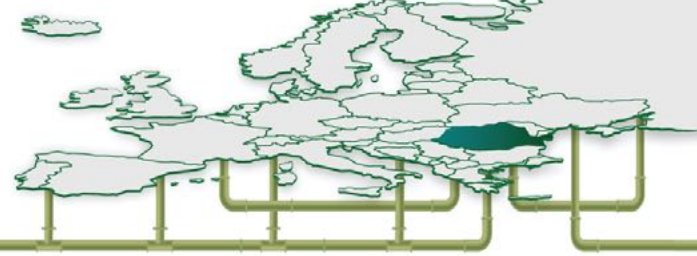

The definition of GRP pipe stiffness classes is given based on the same principle, in ISO standards, as well as in AWWA ones. However, they use different coefficients. The stiffness class is chosen in accordance with two parameters:

1. burial conditions which include natural soil, the type of backfilling material and the height of coverage;
2. the negative pressure.

On demand, pipes with stiffnesses higher than 10,000 Pa or other intermediate stiffnesses can also be manufactured. **For extra information concerning pipes with non-standard lengths or diameters, as well as other pressure or stiffness classes which are not mentioned above, please contact ROREX Marketing Department.**

#### Standard Diameters

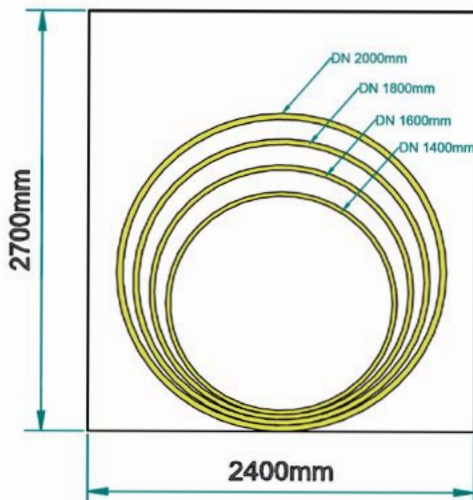

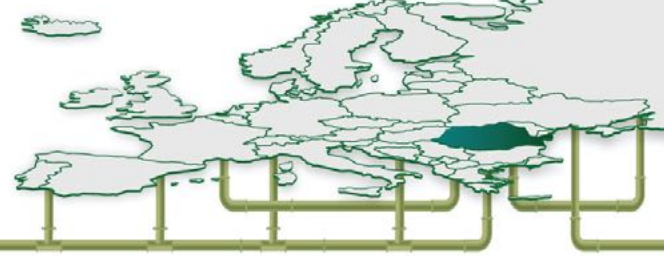

## 7. Pipe Properties

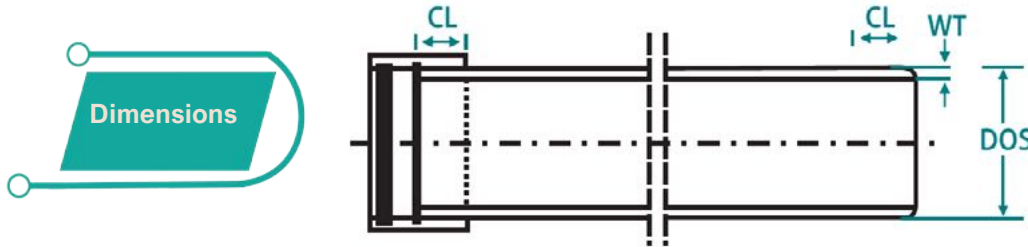

Fig. 10 Sketch of GRP pipe with jointed coupling

Table 1: Nominal diameter (DN), pipe outer diameter (DOS) and its weight for PN 1, PN 6, PN 10, PN 16 and PN 20, where the stiffness class is **SN 2500**

DN	DOS max	WT (mm)				Weight kg/m
		PN1-PN6	PN10	PN16	PN20	
300	324	4.1	3.9	3.8	3.8	8.0
350	362	4.7	4.6	4.4	4.4	10.6
400	413	5.1	4.9	4.8	4.7	12.5
450	464	5.8	5.4	5.3	5.2	15.7
500	515	6.4	5.9	5.8	5.7	19.2
600	617	7.8	7.0	6.7	6.7	27.0
700	719	8.9	8.0	7.7	7.6	37.0
800	821	10.1	9.1	8.6	8.6	48.0
900	923	11.3	10.1	9.6	9.5	60.0
1000	1025	12.5	11.1	10.5	10.5	74.0
1100	1127	13.7	12.2	11.5	11.4	89.0
1200	1229	14.8	13.2	12.5	12.3	106.0
1300	1331	16	14.2	13.4	13.3	124.0
1400	1433	17.1	15.2	14.4	14.2	144.0
1500	1535	18.2	16.2	15.3	15.1	164.0
1600	1637	19.4	17.3	16.3	15.9	187.0
1700	1739	20.8	18.3	17.2		210.0
1800	1841	21.9	19.3	18.2		235.0
1900	1943	23	20.3	19.1		261.0
2000	2045	24.2	21.4	20.1		290.0
2100	2147	25.4	22.4	21.0		319.0
2200	2249	26.5	23.4	22.0		349.0
2300	2351	27.7	24.4	22.9		382.0
2400	2453	28.9	25.4	23.9		415.0
2500	2555	30.0	26.5	24.9		450.0
2600	2657	31.2	27.5	25.9		486.0
2700	2759	32.5	28.5	26.8		523.0
2800	2861	33.7	29.5	27.6		553.0
2900	2963	35.0	30.5	28.6		604.0
3000	3065	35.9	31.5	29.7		654.0
3100	3167	36.0	31.7	29.9		665.0
3200	3269	37.1	32.6	30.8		710.0
3300	3371	38.3	33.6	31.8		790.0
3400	3473	39.4	34.6	32.7		800.0
3500	3575	40.5	35.5	33.6		845.0
3600	3677	41.6	36.6	34.6		895.0
3700	3779	42.8	37.5	35.5		945.0
3800	3881	43.9	38.5	36.5		995.0
3900	3983	45.1	39.5	37.4		1045.0
4000	4085	46.2	40.5	38.3		1100.0

Table 2: Nominal diameter (DN), pipe outer diameter (DOS) and its weight for PN1, PN 6, PN 10, PN 16, PN 20 and PN 25 where the stiffness class is **SN 5000**

DN	DOS max	WT (mm)					Weight kg/m
		PN1-PN6	PN10	PN16	PN20	PN25	
300	324	5.1	5.1	4.8	4.7	4.7	10.3
350	362	5.9	5.8	5.4	5.4	5.4	13.8
400	413	6.6	6.2	5.8	5.8	5.8	16.2
450	464	7.3	6.9	5.8	5.8	5.8	21.0
500	515	8.1	7.6	7.1	7.0	7.0	25.0
600	617	9.6	8.9	8.4	8.2	8.2	36.0
700	719	11.1	10.3	9.6	9.3	9.3	49.0
800	821	12.5	11.6	10.9	10.5	10.5	63.0
900	923	14.0	13.2	12.1	11.8	11.8	80.0
1000	1025	15.4	14.5	13.3	12.9	12.9	99.0
1100	1127	16.9	15.9	14.6	14.2	14.2	119.0
1200	1229	18.3	17.3	15.8	15.3	15.3	141.0
1300	1331	19.9	18.6	17.0	16.5	16.5	165.0
1400	1433	21.4	20.0	18.3	17.8	17.8	191.0
1500	1535	22.9	21.3	19.5	19.0	18.5	219.0
1600	1637	24.3	22.7	20.7	19.9	19.7	249.0
1700	1739	25.8	24.1	22.0			281.0
1800	1841	27.3	25.4	23.2			314.0
1900	1943	28.7	26.8	24.4			350.0
2000	2045	30.1	28.2	25.6			388.0
2100	2147	31.6	29.5	26.9			427.0
2200	2249	33.1	32.9	28.1			468.0
2300	2351	34.5	32.3	29.3			512.0
2400	2453	36.0	33.7	30.6			557.0
2500	2555	37.5	35.0	31.8			604.0
2600	2657	38.7	36.5	33			657.0
2700	2759	41.2	38.0	34.5			708.0
2800	2861	41.9	39.0	35.5			760.0
2900	2963	44.1	40.5	37			814.0
3000	3065	44.8	41.5	38			871.0
3100	3167	45.1	41.6	38.2			885.0
3200	3269	46.5	42.9	39.4			940.0
3300	3371	47.9	44.3	40.6			1000.0
3400	3473	49.3	45.6	41.8			1065.0
3500	3575	50.8	46.9	43.0			1125.0
3600	3677	52.2	48.2	44.2			1190.0
3700	3779	53.7	49.6	45.4			1260.0
3800	3881	55.1	50.9	46.6			1325.0
3900	3983	56.5	52.2	47.8			1400.0
4000	4085	57.9	53.5	49.0			1470.0

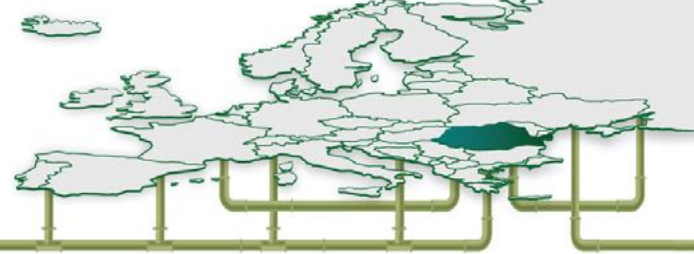

Fig. 10 (pg. 26) GRP pipe sketch with joined coupling

**DOS (mm)** = pipe outer diameter  
**WT (mm)** = wall thickness  
**PN** = pressure class  
 eg. PN 6 - maximum work pressure is 6 bar

**DN (mm)** = nominal diameter  
**SN (kN/m<sup>2</sup>)** = stiffness class  
**CL(mm)** = coupling length

Table 3: Nominal diameter, outer pipe diameter and its weight for PN 1, PN 6, PN 10, PN 16, PN 20, PN 25 and PN 32 where the stiffness class is **SN 10000**

DN	DOS max	WT (mm)						Weight kg/m
		PN1-PN6	PN10	PN16	PN20	PN25	PN32	
100	107.0	3.5	3.5	3.5	3.5			2.0
150	157.6	3.8	3.8	3.8	3.8			3.3
200	209.8	4.9	4.9	4.9	4.9			5.8
250	262.0	6.0	6.0	6.0	6.0			8.9
300	324.0	6.2	6.2	6.0	5.8	5.7	5.7	12.7
350	362.0	7.2	7.2	6.8	6.7	6.6	6.5	17.4
400	413.0	7.8	7.8	7.4	7.2	7.1	7.0	21.0
450	464.0	8.8	8.8	8.2	8.0	7.9	7.8	26.0
500	515.0	9.8	9.8	9.0	8.8	8.6	8.5	33.0
600	617.0	11.7	11.7	10.7	10.4	10.2	10.0	48.0
700	719.0	13.7	13.7	12.3	11.9	11.7	11.5	65.0
800	821.0	15.5	15.5	14.0	13.5	13.2	13.0	85.0
900	923.0	17.3	17.3	15.6	15.1	14.7	14.5	107.0
1000	1025.0	19.2	19.2	17.2	16.6	16.2	16.0	132.0
1100	1127.0	21.2	21.2	18.9	18.2	17.7	17.5	160.0
1200	1229.0	23.0	23.0	20.5	19.7	19.3	19.0	190.0
1300	1331.0	24.8	24.8	22.1	21.3	21.8	20.4	223.0
1400	1433.0	26.7	26.7	23.7	22.9	22.3	21.9	258.0
1500	1535.0	28.4	28.4	25.4	23.9	23.8	23.1	295.0
1600	1637.0	30.3	30.3	27.0	25.4	24.8	24.5	336.0
1700	1739.0	31.0	32.1	28.6				378.0
1800	1841.0	34.0	34.0	30.3				423.0
1900	1943.0	35.8	35.8	31.9				472.0
2000	2045.0	37.6	37.6	33.5				521.0
2100	2147.0	39.5	39.5	35.1				574.0
2200	2249.0	42.7	42.7	38.0				630.0
2300	2351.0	44.6	44.6	39.7				688.0
2400	2453.0	46.5	46.5	41.4				748.0
2500	2555.0	47.2	47.7	41.7				822.0
2600	2657.0	47.9	49.5	43.3				888.0
2700	2759.0	50.8	51.3	44.9				955.0
2800	2861.0	51.3	53.1	46.5				1025.0
2900	2963.0	54.5	55.0	48.2				1102.0
3000	3065.0	55.1	55.8	49.7				1176.0
3100	3167.0	56.4	56.0	49.8				1200.0
3200	3269.0	58.2	57.7	51.4				1275.0
3300	3371.0	60.0	59.5	53.0				1355.0
3400	3473.0	61.8	61.3	54.5				1440.0
3500	3575.0	63.6	63.1	56.1				1525.0
3600	3677.0	65.4	64.9	57.7				1615.0
3700	3779.0	67.2	66.7	59.3				1705.0
3800	3881.0	69.0	68.4	60.9				1800.0
3900	3983.0	70.7	70.2	62.4				1895.0
4000	4085.0	72.5	72.5	64.0				1995.0

Notă: The values from the table are determined based on ROREX production standards. Due to the different raw materials, these values can vary.

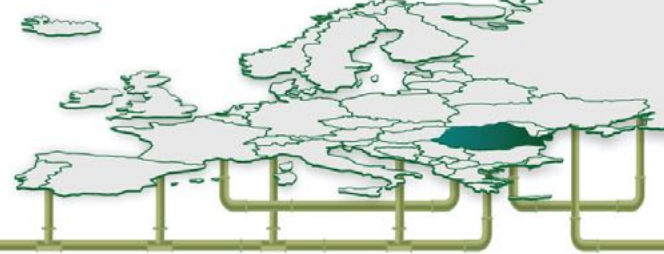

**Load capacity  
(strength)  
Values**

For design purposes, the values from Table 4 can be used for hoop tensile load capacity. The values from [Table 5 \(pg. 29\)](#) can be used for axial tensile load capacity. [Fig. 11 \(pg. 29\)](#) presents the different types of tensile loads that a pipe is subjected to once it is installed.

*Table 4: Hoop (circumferential) load capacity (strength), in N/mm of circumference*

<b>DN</b>	<b>6</b>	<b>10</b>	<b>16</b>	<b>20</b>	<b>25</b>	<b>32</b>
100	120	200	319	400	500	640
150	180	300	478	600	750	960
200	240	400	639	800	1000	1280
250	300	500	798	1000	1250	1601
300	360	600	957	1200	1500	1920
350	420	700	1117	1400	1750	2240
375	450	750	1197	1500	1876	2400
400	480	800	1276	1600	2000	2560
450	540	900	1436	1800	2250	2880
500	600	1000	1595	2000	2500	3200
550	660	1100	1755	2200	2750	3520
600	720	1200	1915	2400	3000	3840
700	840	1400	2234	2800	3500	4480
750	900	1500	2393	3000	3750	4801
800	960	1600	2553	3200	4000	5120
850	1020	1700	2712	3400	4250	5440
900	1080	1800	2871	3600	4500	5760
1000	1200	2000	3191	4000	5000	6400
1100	1320	2200	3510	4400	5500	7040
1150	1380	2300	3669	4600	5750	7360
1200	1440	2400	3829	4800	6000	7680
1300	1560	2600	4148	5200	6500	8320
1400	1680	2800	4467	5600	7000	8960
1500	1800	3000	4786	6000	7500	9600
1600	1920	3200	5105	6400	8000	10240
1700	2040	3400	5425	6800	8500	10880
1800	2160	3600	5743	7200	9000	11520
1900	2280	3800	6062	7600	9500	12160
2000	2400	4000	6381	8000	10000	12800
2100	2520	4200	6701	8400	10500	13440
2200	2640	4400	7020	8800	11000	14080
2300	2760	4600	7338	9200	11500	14720
2400	2880	4800	7658	9600	12000	15360
2500	3000	5000	7977	10000	12500	16000
2600	3210	5200	8296	10400	13000	16640
2700	3240	5400	8615	10800	13500	17280
2800	3360	5600	8934	11200	14000	17920
2900	3480	5800	9253	11600	14500	18560
3000	3608	6000	9572	12000	15000	19200
3100	3726	6200	9891	12400	15500	19840
3200	3844	6400	10210	12800	16000	20480
3300	3962	6600	10529	13200	16500	21120
3400	4080	6800	10848	13600	17000	21760
3500	4200	7000	11168	14000	17500	22400
3600	4320	7200	11487	14400	18000	23040
3700	4440	7400	11806	14800	18500	23680
3800	4560	7600	12125	15200	19000	24320
3900	4680	7800	12444	15600	19500	24960
4000	4800	8000	12763	16000	20000	25600

Note: The values from these table were calculated referring to AWWA and ASTM standards

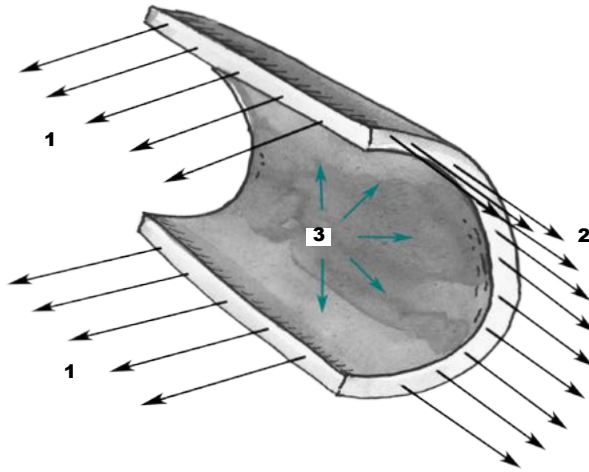
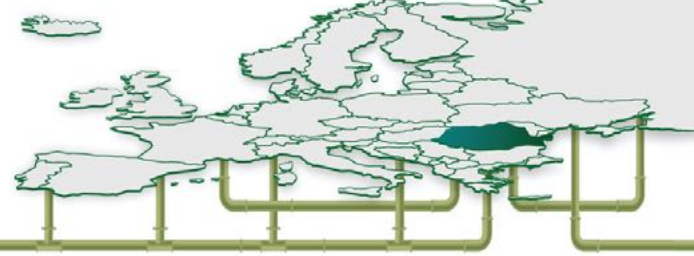
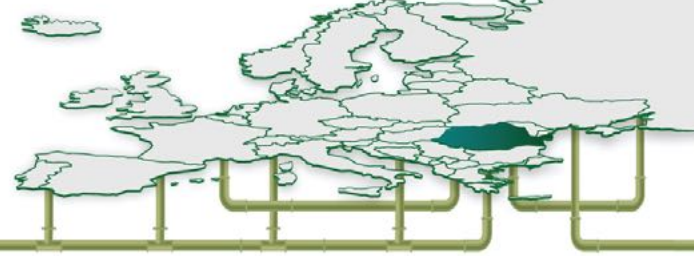

Fig. 11 Sketch which illustrates the different types of loads a pipe is subjected to during its operation period, where:  
1 - hoop load  
2 - longitudinal load  
3 - pressure

Table 5: Axial (longitudinal) load capacity (strength), in N/mm of length

DN	6	10	16	20	25	32
100	75	80	90	100	110	125
125	80	90	100	110	120	135
150	85	100	110	120	130	145
200	95	110	120	135	150	155
250	105	125	135	155	170	190
300	110	140	155	175	200	220
400	130	165	190	215	250	285
500	145	190	225	255	300	345
600	160	220	255	295	350	415
700	175	250	290	335	400	475
800	190	280	325	380	450	545
900	205	310	360	420	505	620
1000	225	340	395	465	555	685
1200	255	380	465	540	645	790
1400	290	420	530	620	745	915
1600	320	460	600	700	845	1040
1800	350	500	670	785	940	1160
2000	385	540	740	865	1040	1285
2200	415	575	810	945	1140	1410
2400	450	620	880	1025	1240	1530
2600	480	665	945	1110	1335	1655
2800	515	710	1015	1190	1435	1780
3000	545	755	1080	1270	1535	1900
3200	575	805	1150	1350	1630	2025
3400	610	850	1220	1430	1730	2150
3600	645	895	1290	1515	1830	2250
3800	680	940	1355	1595	1930	2400
4000	715	985	1425	1675	2025	2520

Note: The values from these table were calculated referring to ISO and EN standards



**Poisson's ratio**

Poisson's ratio is influenced by pipe construction. For ROREX GRP pipes, the ratio between the circumferential dimensions modifications, due to hoop (circumferential) loads and axial ones is in the range 0.22 - 0.29. For axial load and hoop response, Poisson's ratio will be slightly smaller.

**UV radiation resistance**

The stability of GRP material to UV radiation emitted by the sun is especially necessary for the case of above-ground applications. The tests have shown that the degradation under the action of UV rays is not a significant issue during the lifetime of GRP pipes.

**Expansion**

The thermal expansion/contraction coefficient on the axial direction of GRP pipes is **24 - 30** x 10<sup>-6</sup> cm/cm/°C.

**Abrasion resistance**

Abrasion resistance is associated with the effect of granular materials' movement on the interior surface of the pipe. ROREX GRP pipes were evaluated using the Darmstadt method (Fig. 12). Using abrasive granular material, the average abrasion loss is 0.34 mm/100,000 cycles. The results can vary depending on the abrasive material used in the test.

Fig. 12 Sketch which illustrates the Darmstadt test for establishing abrasion resistance

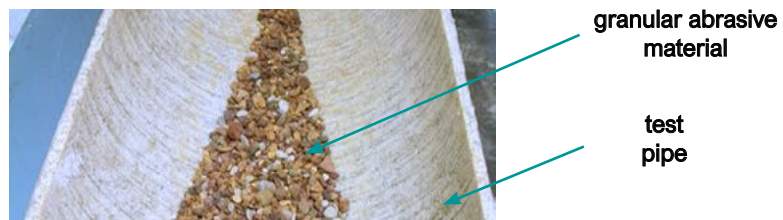



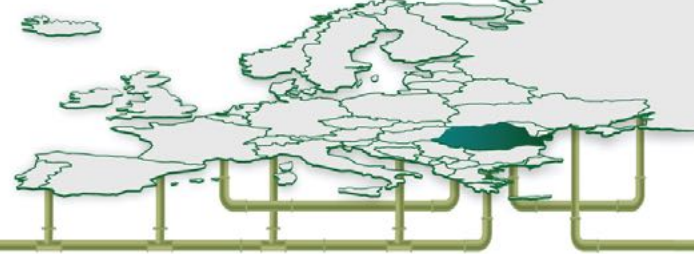

**Hydraulic properties**

According to the tests, the roughness coefficients for GRP pipes are the following:

- » Colebrook - White coefficient,  $f = 0.029$ , to whom the subsequent correspond:
- » the coefficient from the Hazen-Williams formula,  $C = 150-160$
- » Mannings roughness coefficient,  $n = 0.009$
- » the friction coefficient from the Darcy-Weisbach equation,  $f_D = 0.00518$

These favorable flow coefficients are due to the pipe's extremely smooth internal surface.

On account of the pipes' corrosion resistance, the flow coefficients don't change during the service life.

For a given flow, a smaller diameter GRP pipe can be chosen instead of a pipe manufactured from a different material. For example, one can demonstrate that a 1800 mm GRP pipe transports the same flow, with the same head losses as a steel pipe which has a diameter of 2000 mm.

Hazen-Williams equation:

$$HF = \frac{10.68 \times Q^{1,852} \times L}{C^{1,852} \times D^{4.87}}$$

HF - head loss (m),  
Q - discharge (m<sup>3</sup>/s),  
L- length of pipeline (m),  
D - pipe diameter (m),  
C - roughness coefficient

$C_{steel} = 110$   
 $C_{GRP} = 150$

$Q_{steel} = Q_{GRP}$   
 $L_{steel} = L_{GRP}$   
 $HF_{steel} = HF_{GRP}$   
 $D_{osteel} = 2000 \text{ mm}$

The head loss (or pressure drops) appear in all the pipe systems due to sudden directional changes or friction that appears inside the pipes and couplings. The graphs of head loss values as a function of flow in GRP pipes are presented on the next page.

[Fig. 13](#) (pg. 32) refers to pipes which have PN 10 and SN 5000, and [Fig. 14](#) (pg. 32) refers to small diameter pipes.

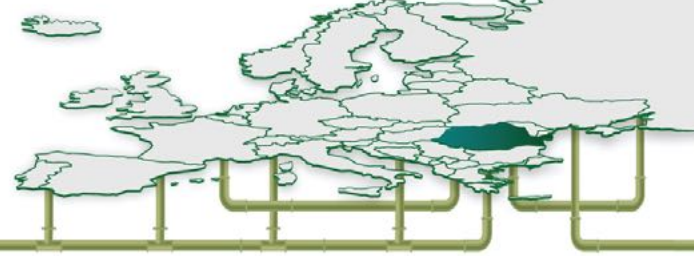

Fig. 13 Head loss as a function of transported flow and GRP pipe diameter with PN 10 and SN 5000

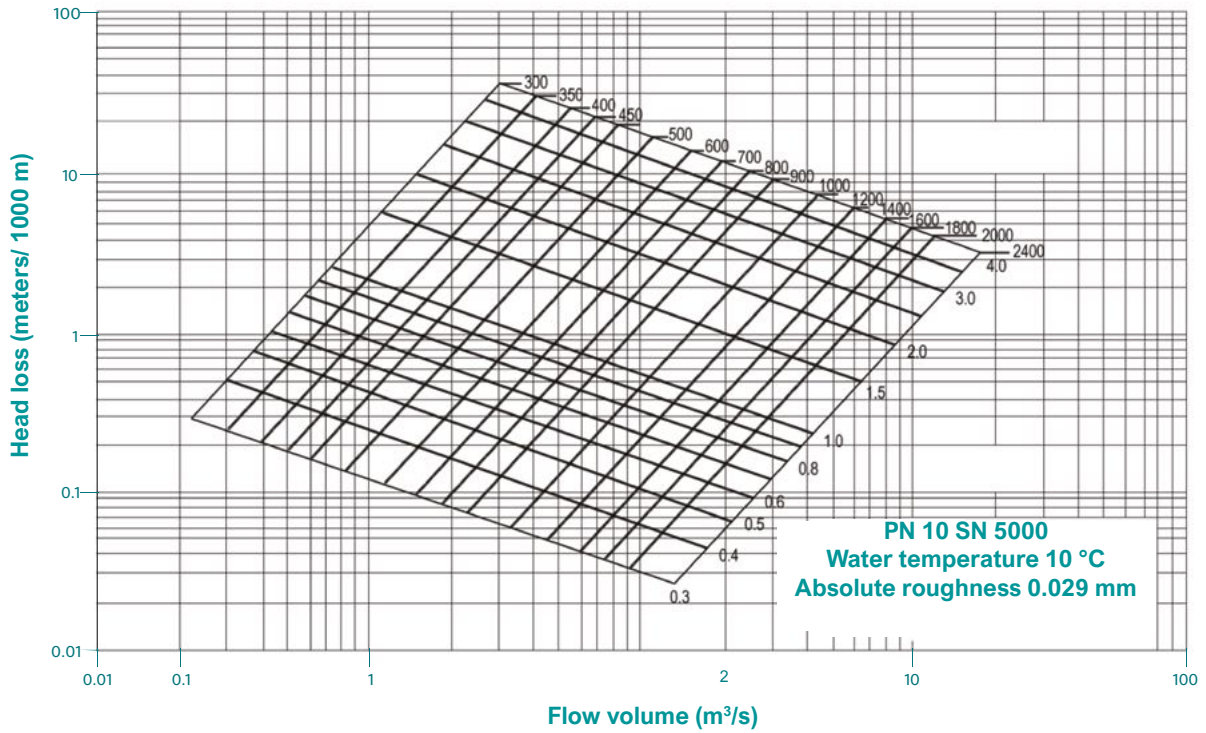
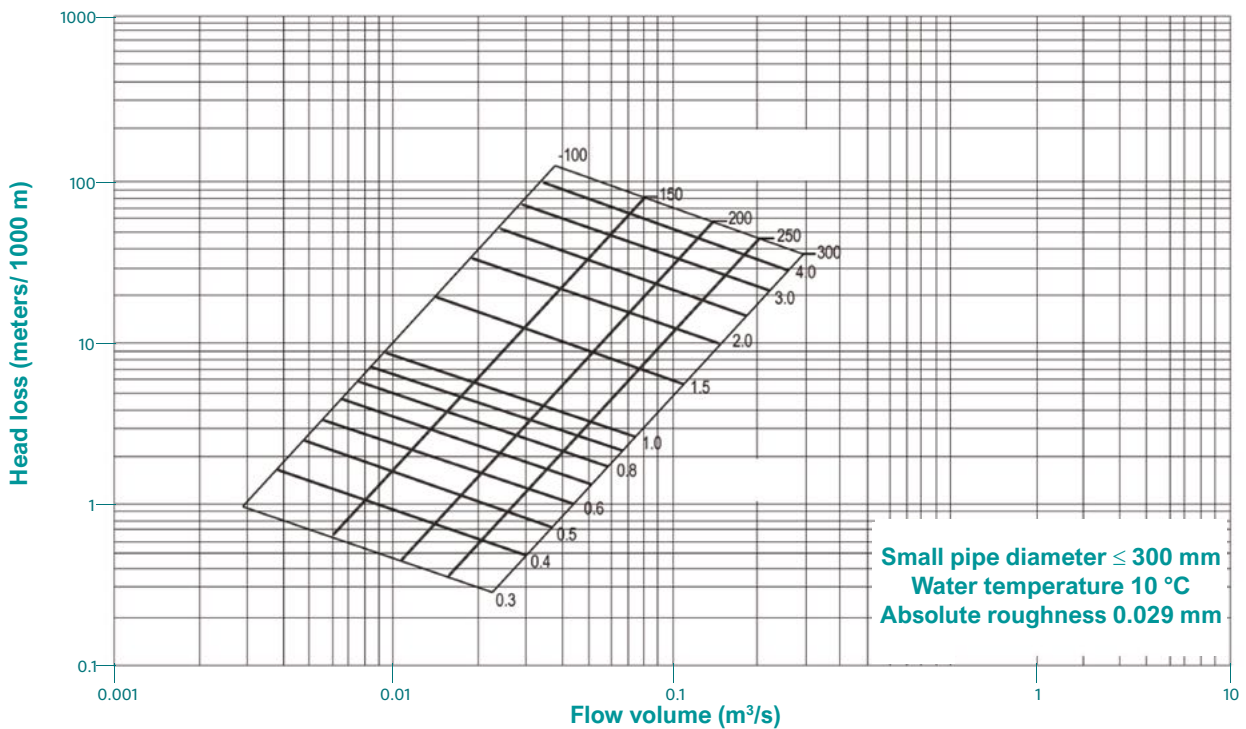
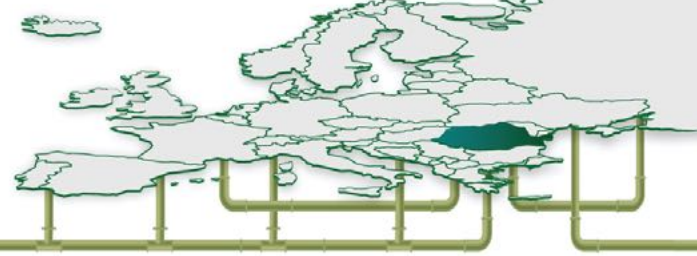

Fig. 14 Head loss as a function of transported flow and GRP pipe diameter with DN ≤ 300 mm







## 8. Quality Control for Finished Pipes

All finished uniaxial GRP pipes are subjected to the following control steps:

- » Visual inspection
- » Barcol hardness
- » Wall thickness
- » Length measurement
- » Diameter measurement
- » Hydrostatic Pressure Test (2x nominal pressure)

Subsequently, a step-wise control is performed, on samples. This shows the pipes' initial physical properties and encompasses the following tests:

- » Pipe stiffness
- » Inner surface control under the deflection load
- » Structural failure control under the deflection load
- » Composite structure analysis and design verification
- » Hoop (circumferential) tensile strength
- » Axial (longitudinal) tensile strength
- » Washing with water jet at 120 atm (only for sewerage pipes)

The most important tests are the ones that are aimed at the performance of pipes on a long term. Taking into consideration different operating conditions, the following tests are done:

- » Long term specific ring stiffness
- » Long term ring bending strain
- » Hydrostatic design basis (HDB)
- » Long term strain corrosion

For special applications pipes, the following extra tests are done

- » Ultraviolet (UV) resistance
- » Abrasion resistance
- » Flow velocity
- » Resistance to different operating temperatures
- » Fire resistance

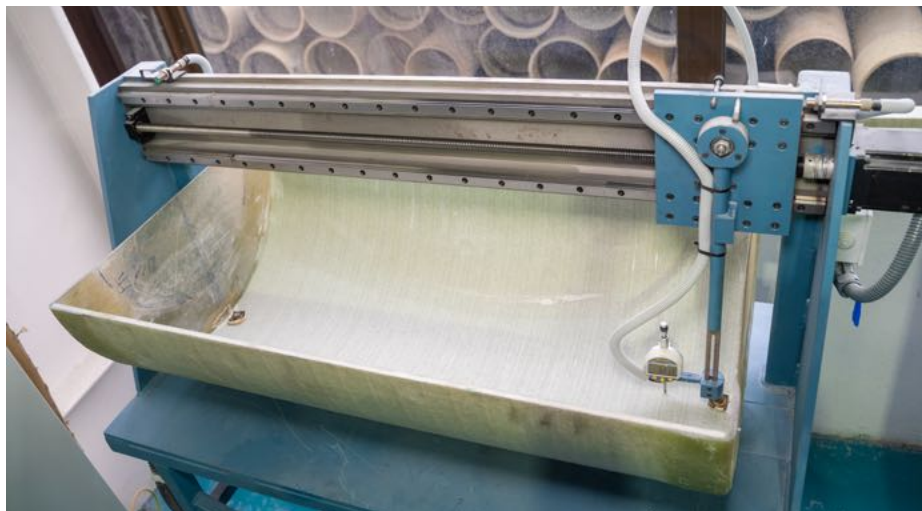
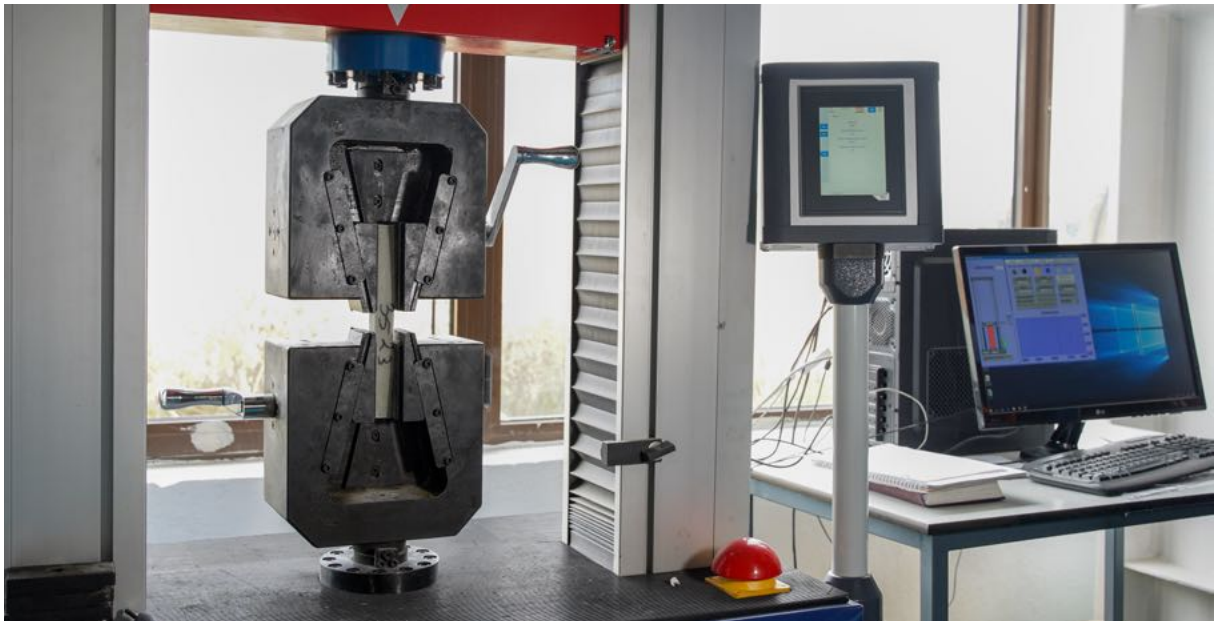
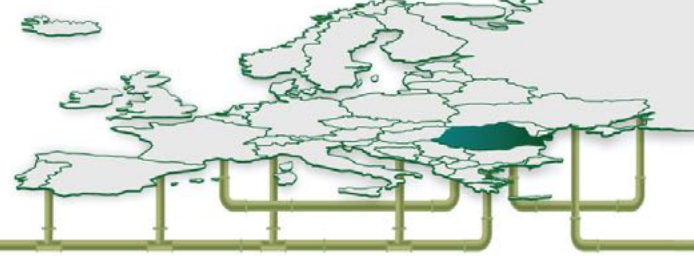

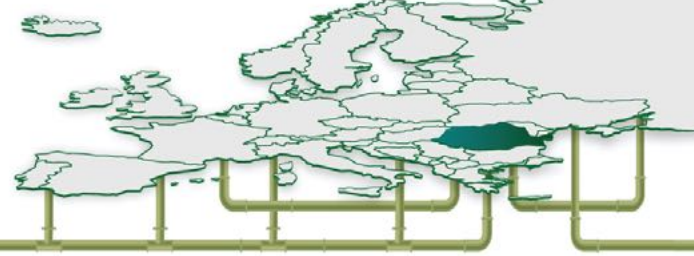

## 9. Considerations on Design and Proper Operation

### Hydrostatic Pressure Test

**Max. plant test pressure :** 2.0 x PN (Nominal Pressure)  
**Max. field test pressure:** 1.5 x PN (Nominal Pressure)

Performing a correct pressure test in safe conditions requires the correct selection and installation of equipment, as well as of the other constructions in the field.

### Pressure Surge/ Water Hammer

**Maximum Pressure** 1.4 x PN (Nominal Pressure)

Water hammer or pressure surge is the sudden increase or drop in the pressure caused by an abrupt change in fluid velocity within the pipe system.

The most frequent causes of these flow changes are: i. the rapid opening or closing of the valves, ii. the pumps turning on or off suddenly as a result of a power failure.

The most important factors which influence water hammer are: variation in fluid velocity, rate of change of the velocity (valve closing time), fluid compressibility, stiffness of the pipe in the hoop direction, and physical layout of the pipe system. The water hammer pressure for GRP pipes is up to 50% less than the one for ductile iron or steel pipes.

An approximate relationship for maximum pressure variation at a given point in a straight pipeline with negligible friction loss can be calculated from the formula:

$$\Delta H = \frac{W \cdot \Delta V}{g}$$

$\Delta H$  = change in pressure (m)

$W$  = surge wave celerity (m/s)

$\Delta V$  = change in liquid velocity (m/s)

$g$  = acceleration due to gravity (m/s)

Surge wave celerity in GRP pipes (m/s) for different stiffness classes is given in Table 6, pg. 37.

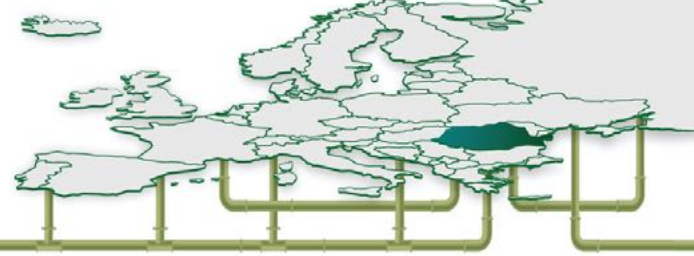
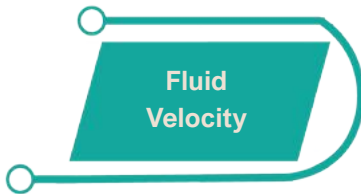

Table 6: Surge wave celerity in GRP pipes (m/s) for stiffness classes SN 2500, SN 5000, SN 10000

SN 2500				SN 5000			
DN	300-400	450-800	900-2500	DN	300-400	450-800	900-2500
PN6	365	350	340	PN6	405	380	370
PN10	435	420	405	PN10	435	420	410
PN16	500	490	480	PN16	505	495	485
				PN25	575	570	560

SN 10000								
DN	100	125	150	200	250	300-400	450-800	900-2500
PN6	580	560	540	520	500	420	415	410
PN10	590	570	560	540	520	435	425	415
PN16	640	620	610	600	590	500	495	485
PN25						580	570	560
PN32						620	615	615



The maximum recommended flow velocity is 3.0 m/s. Velocities up to 5.0 m/s can be accepted if the water is clean and does not contain abrasive material.

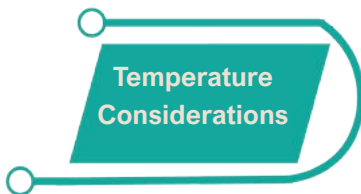

The maximum permitted temperature of the fluid is 45°C. ROREX recommends decreasing the pressure class when the temperature is between 46°C and 60°C. For example PN 16 pipes will be used for a pressure of PN 10. The pipe resistance can be increased to 100°C by using adequate types of resin.



*Installation of a GRP Uniaxial Pipeline DN 2800*







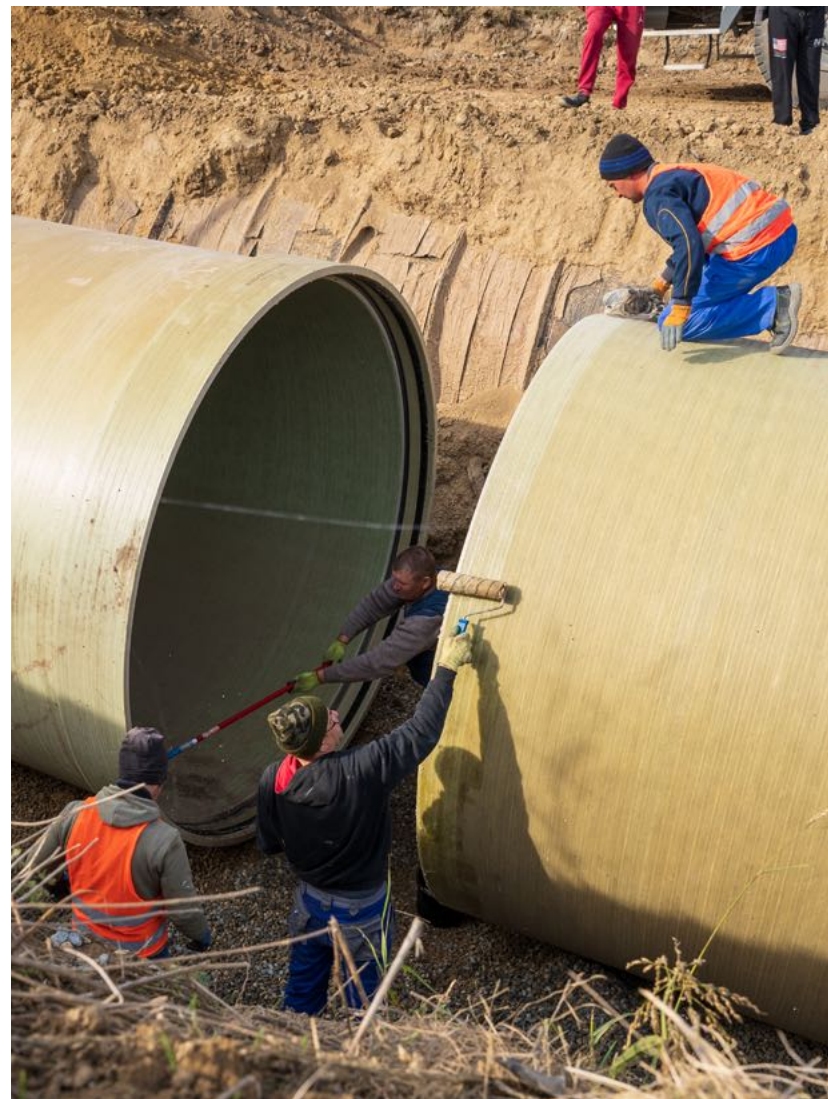



Installation of a Pipeline With Metal-GRP Crossing



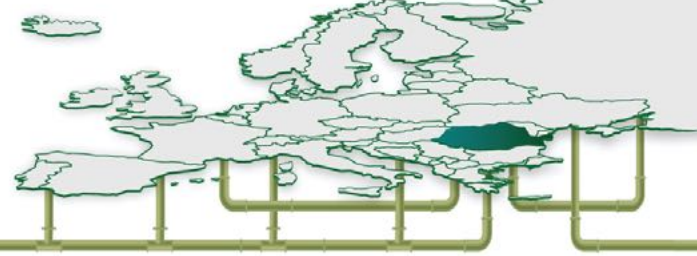

## 10. Pipes for Special Applications

Apart from the standard uniaxial pipes, ROREX also manufactures pipes for special applications such as: biaxial pipes, no-sand pipes, jacking pipes.

### 10.1 Biaxial Pipes

Biaxial pipes are made to resist forces in the axial direction as well as in the circumferential direction. This reinforcement requires a different wall construction than uniaxial pipes, having less sand and more glass fibers.

This type of pipes are designed for above-ground applications, as well as for conditions where the soil is weak and offers little support, or in establishments where thrust blocks cannot be placed. Likewise, this type of pipes are used for undersea applications. Examples of applications (Fig. 15) can be: cooling water, desalinization. In this type of pipe, the action of axial forces due to the directional changes is taken over by the pipe and its couplings.



*Fig. 15 Overground applications examples that use overground biaxial pipes*

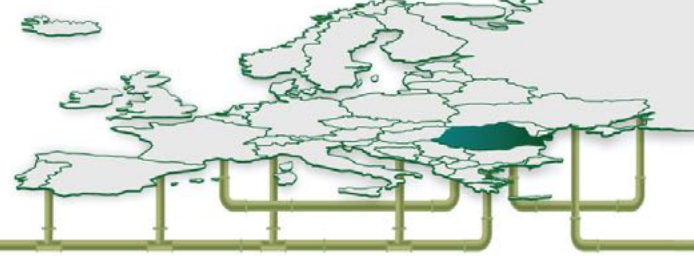

Biaxial pipes can be joined together only by using restrained (blocked) couplings: glued couplings (combi), laminated (lay-up) joints, flanges. More details on all types of couplings can be found in [Chapter 11 Pipe Joining Elements](#), pg. 48. Table 7 shows the physical properties of ROREX biaxial pipes, together with the ones for recommended laminated joints.

*Table 7: ROREX biaxial pipes physical properties and ROREX recommended laminated joints physical properties*

Physical Properties	Biaxial pipes		Laminated joints	
	Hoop	Axial	Hoop	Axial
$E_T$ , tensile modulus (GPa)	20.0	13.10	-	10.3
$E_T$ , flexural modulus (GPa)	18.6	12.00	-	10.3
$\sigma_{UTS}$ , ultimate tensile stress (MPa)	380.0	158.00	-	138.0
$\nu$ , Poisson's ratio	0.2	0.25	-	0.3
$\alpha$ , linear thermal coefficient (cm/cm/°C)	9.0	12.60	-	27.0
G, shear modulus (GPa)	3.3	3.30	-	3.1
$\tau_{ULT}$ , ultimate shear stress (MPa)	46.9	19.00	-	138.0
Tensile allowable stress (MPa)	62.0	26.40	23.0	23.0
Flexural allowable stress (MPa)	62.0	26.40	23.0	23.0
Shear allowable stress (MPa)	7.8	7.80	5.7	5.7

In most above-ground biaxial pipe installations, joints are monoblock bound together to resist tensile forces acting on each pipe due to internal pressure.

Above-ground biaxial GRP pipes are installed on special supports (Fig. 16). Spacing between supports can be calculated by flexibility analysis.

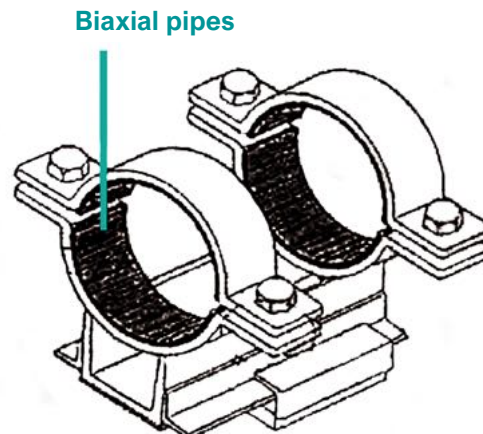

*Fig. 16 Special supports for biaxial pipes*

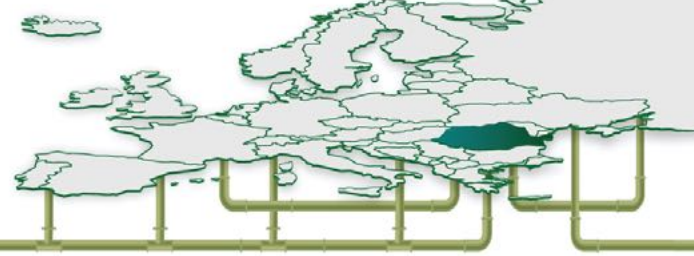

## 10.2 No-sand Pipes

The greatest advantages of no-sand GRP pipes (Fig. 17) are their superior mechanical properties due to high glass fiber content. This leads to a much higher safety factor during the service time.

For example, for a pipe DN 800, PN 10, SN 5000:

» **There is a superior impact resistance, and significantly better resistance to blows during manipulation and installation.**

Through measurements, it has been observed that the impact resistance for a no-sand pipe is much higher than for pipes which contain sand, because they absorb the energy much better, since there is a very strong chemical bond between the individual pipe wall layers. Table 8 presents the differences between various mechanical properties of pipes with sand and no-sand pipes.

*Table 8: Mechanical properties of pipes with sand and no-sand pipes*

Mechanical property	With sand	No sand	Difference
Hoop tensile strength [MPa]	180.0	683.0	379%
Axial tensile strength [MPa]	30.5	58.2	191%
Hoop tensile modulus [GPa]	13.1	38.5	294%
Axial tensile modulus [GPa]	6.8	12.7	187%



*Fig. 17 No-sand pipe*

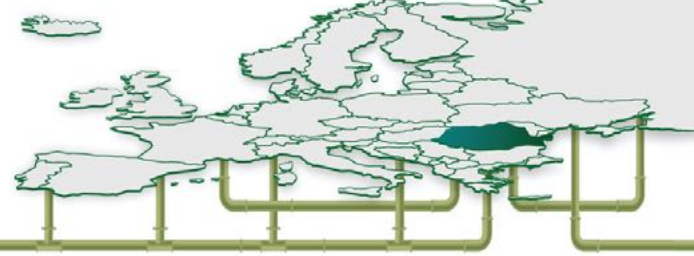

» **Longer service period, due to the increase in the long term behavioral properties of the pipes**

No-sand pipes correspond to a recipe for a 32 bar pipe, therefore the safety factor in long term service is 3x bigger than a normal 10 bar pipe that contains sand. The estimated life time is thus 3x higher (Fig. 18).

Fig. 18 Hydrostatic Design Basis (ASTMD-2992) DN 600, PN 10, SN 5000 long term pressure test

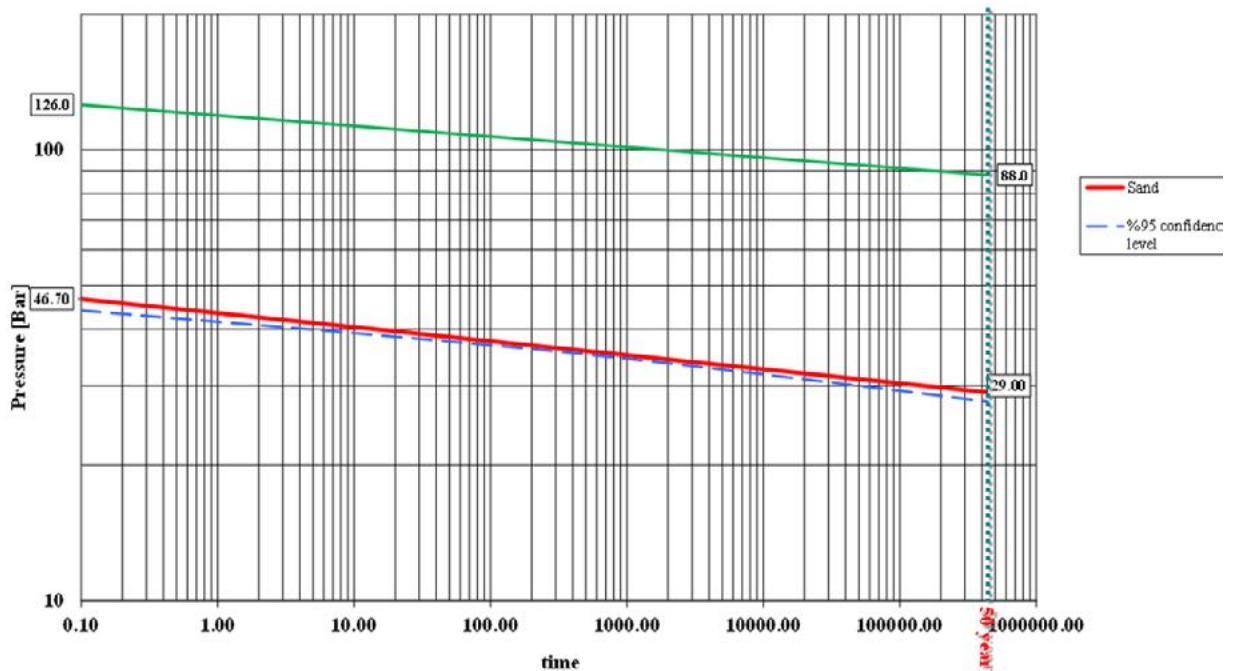

» **Lower risk of manufacturing defects, because there is one less parameter to control in the production process, hence it is a better controlled process.**

Table 9 presents the raw materials list for GRP pipes DN 700, SN10000, with sand (PN10) and without sand (PN32).

Table 9: Raw materials for several GRP Pipes DN 700, SN 10000 - pipes with sand and no-sand pipes

Raw materials	With sand (PN10)		No sand (PN32)	
	Kg/m	%	Kg/m	%
Fiberglass	11.53	17.65	36.54	72.88
Resin	16.41	25.11	13.60	27.12
Sand	37.40	57.24	-	-
<b>Total</b>	<b>65.34</b>	<b>100.00</b>	<b>50.14</b>	<b>100.00</b>

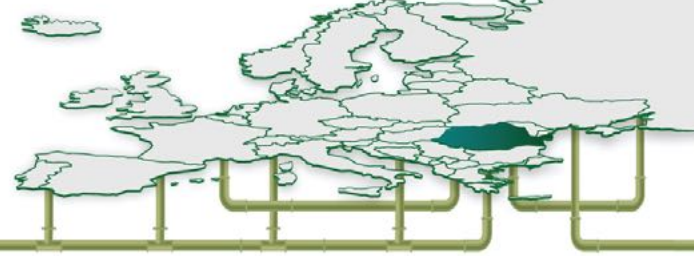

» **Smaller hydraulic losses for the same nominal diameter**

Table 10 presents the diameters and wall thicknesses for several GRP pipes DN 700, SN 1000, with sand (PN 10) and no-sand (PN 32).

*Table 10: Diameters and wall thicknesses for several GRP pipes with sand (PN 10) and no-sand (PN 32), DN 700, SN 10000*

	With sand (PN10)	No-sand (PN 32)	Difference
Dimensions	mm	mm	mm
External diameter	719.0	719.0	-
Wall thickness	13.70	10.50	3.20
Interior diameter	691.60	698.00	(6.40)

**5% smaller head loss**

### 10.3 Jacking Pipes

**Jacking pipes** (Fig. 19) are made to resist a high jacking force (700 - 1000 tonnes), over long distances (30 - 100 m). This requires a much thicker wall than standard uniaxial pipes. Generally, their length is max. 3 m, in order for them to be easily maneuvered throughout the entire process, especially in the vertical jacking shaft which leads to the working base (Fig. 20).



*Fig. 19 Jacking pipe ready for installation*



*Fig. 20 Jacking pipe lowered in the working base*

The pipe installation system using the pipe jacking method, or trenchless horizontal drilling, is generally used for pipe installation in areas with intense traffic, metropolitan areas or densely populated areas, where the installation of pipes using standard excavation methods would lead to significant economic and social losses. In these cases, the method is efficient from a financial point of view, decreasing the cost of the project substantially com-



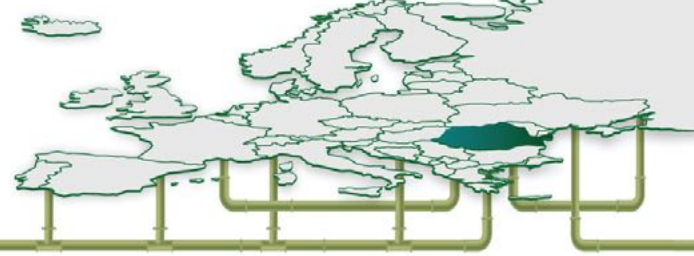

pared to the classic method. Pipe jacking consists of drilling a shaft, usually with a depth of 15 - 20m, where a shield that has a rotating cutting head is lowered. This drills horizontally and is pushed the desired distance by a hydraulic jack. Once the drilling begins, the pipes are also pushed by the hydraulic jack (Fig. 21). Fig. 22 shows an under-crossing and a thrust block.

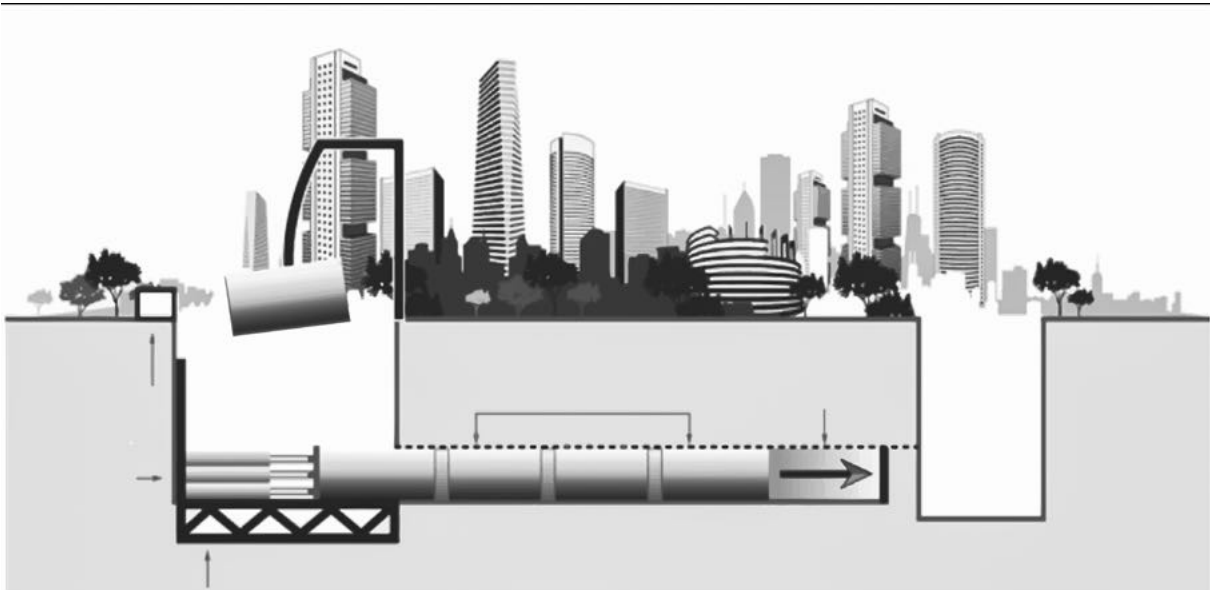

Fig. 21 Pipe jacking process sketch

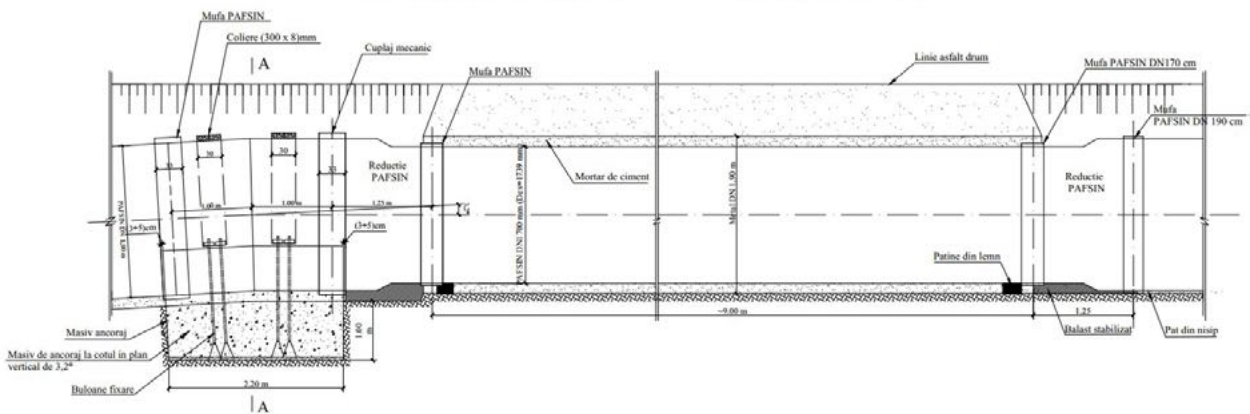
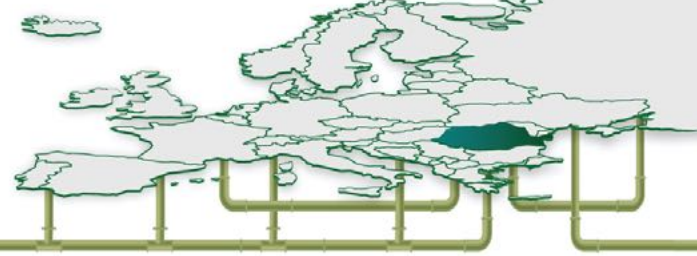

Fig. 22 Under-crossing and thrust block for the elbows in vertical plane



## 10.4 Relining

GRP pipes can also be used for old pipe rehabilitation through relining - the insertion of a smaller diameter pipe right next to the affected area within the pipe that needs rehabilitation (Fig. 23). GRP pipes are excellent candidates due to their high flexibility which allows them to be manufactured at a customised dimension, very close to the original pipe.

Fig. 23 Old pipe rehabilitation through relining with a GRP pipe

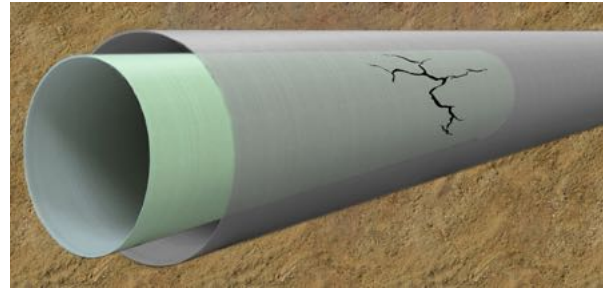

## 11. Pipe Joining Elements

Pipe joining elements are special parts (couplings) used to join two pipes together. There are two types of pipe joining elements: unrestrained and restrained (Fig. 24). The unrestrained couplings are not bonded to the pipes, therefore these offer the pipes degrees of freedom for axial and radial movement. Restrained couplings are bonded to the pipes, therefore the pipes have no degree of freedom of movement after the coupling (connection) has been completed.

For uniaxial pipes, unrestrained joining elements are generally used, and the usage of thrust blocks is necessary. These take over the loads which appear when there are directional changes.

For biaxial pipes, only restrained joining elements are used.

ROREX offers several types of GRP pipe joining elements. Below, we present the most frequently used models. For supplementary information on these, as well as on their installation and preparation, or other types of joining elements, please consult ROREX Marketing Department.

Fig. 24 Pipe joining elements

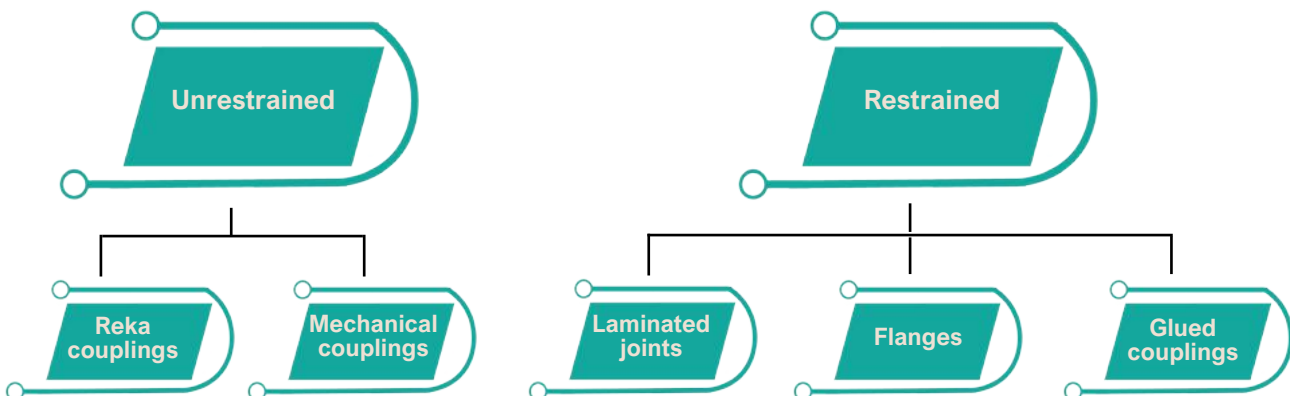

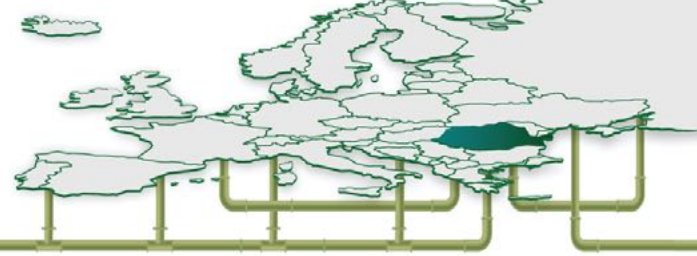

## 11.1 Unrestrained Pipe Joining Elements

### 11.1.1 Reka Couplings

Reka couplings (Fig. 25 a) și b), Fig. 26) are made from GRP and are used to join together uniaxial pipes, and the sealing is done with elastomeric rubber gaskets (EPDM). They have been successfully used for over 50 years and can be installed on a slope or in different soil conditions. They are available for a wide range of diameters (DN 100 mm-DN 4000 mm) and pressure classes (PN 1 bar - PN 32 bar) - Table 11 (pg. 50). These couplings allow an angular deflection of up to 3°, depending on the diameter of the pipe and on the pressure class, thus reducing the number of necessary elbows in the pipe network.

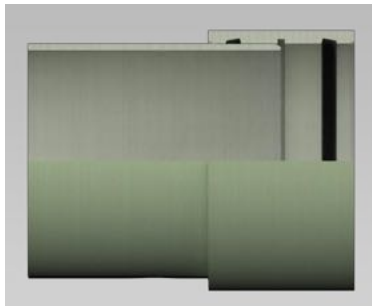
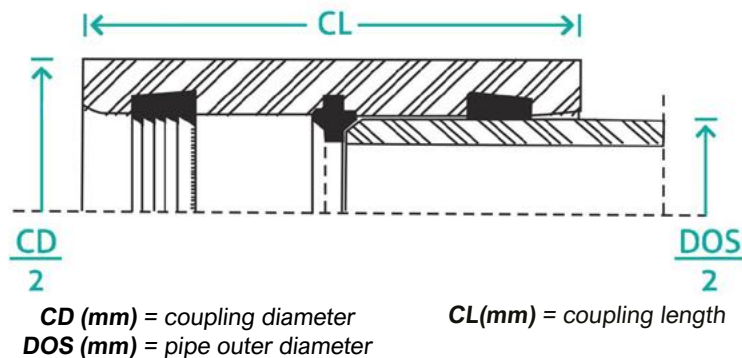

Fig. 25 a) Reka coupling



Fig. 25 b) Reka coupling in preparation for installation on an end of a GRP pipe

Fig. 26 Sketch of a Reka coupling connected to a GRP pipe



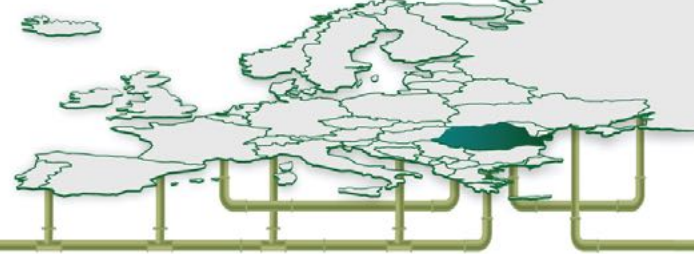
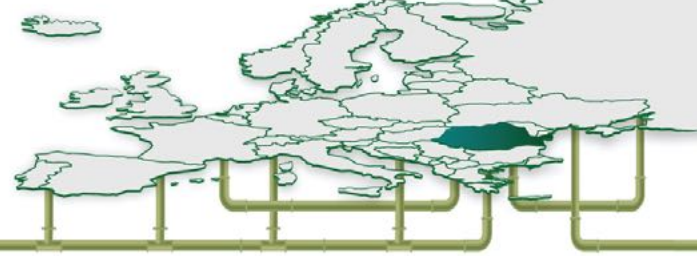

Table 11: Reka couplings dimensions

DN	DOS max (mm)	Coupling ID min (mm)	CD (mm)						CL (mm)
			PN6	PN10	PN16	PN20	PN25	PN32	
100	107.0	107.6	133.6	133.6	134.0	134.4	134.8	138.6	150
150	157.6	158.2	184.2	184.2	184.8	185.2	185.8	189.6	150
200	209.8	211.4	249.6	249.6	250.6	251.2	252.0	257.4	175
250	262.0	263.6	301.8	301.8	303.2	304.0	304.8	310.4	175
300	324.0	327.0	366.0	367.0	368.1	368.6	369.2	375.9	270
350	362.0	363.5	403.3	404.9	406.7	407.6	412.7	447.9	270
400	413.0	414.5	454.1	456.1	458.1	462.4	463.7	468.7	270
450	464.0	465.5	504.9	506.5	508.7	513.0	513.9	519.3	270
500	515.0	516.5	555.7	557.7	559.3	563.4	564.3	571.1	270
600	617.0	618.5	664.1	665.9	668.1	673.2	675.9	683.7	330
700	719.0	720.5	765.9	768.3	772.5	778.2	781.1	792.1	330
800	821.0	822.5	867.7	871.7	876.7	882.8	883.7	896.9	330
900	923.0	924.5	970.7	975.1	980.9	984.8	988.7	1001.7	330
1000	1025.0	1026.5	1073.5	1078.5	1084.7	1089.2	1098.1	1106.5	330
1100	1127.0	1128.5	1176.3	1181.5	1183.0	1193.4	1208.0	1121.7	330
1200	1229.0	1230.5	1278.9	1284.5	1289.9	1299.4	1315.3	1316.7	330
1300	1331.0	1332.5	1318.3	1387.3	1393.3	1407.4	1421.1	1422.1	330
1400	1433.0	1434.5	1483.9	1490.1	1497.5	1515.6	1527.1	1527.1	330
1500	1535.0	1536.5	1586.3	1592.9	1602.7	1621.2	1632.9	1646.0	330
1600	1637.0	1638.5	1688.7	1695.5	1707.3	1722.3	1739.1	1750.0	330
1700	1739.0	1740.5	1791.1	1798.3	1812.1				330
1800	1841.0	1842.5	1893.5	1900.9	1916.1				330
1900	1943.0	1944.5	1995.9	2003.3	2020.0				330
2000	2045.0	2046.5	2098.3	2105.9	2123.5				330
2100	2147.0	2148.5	2200.5	2208.9	2226.9				330
2200	2249.0	2250.5	2302.9	2311.9	2330.3				330
2300	2351.0	2352.5	2405.3	2414.7	2433.3				330
2400	2453.0	2454.5	2507.5	2517.9	2536.3				330
2500	2555.0	2556.5	2559.7	2620.9	2639.3				330
2600	2657.0	2658.5	2690.0	2695.0	2701.0				360
2700	2759.0	2760.5	2792.5	2797.8	2803.2				360
2800	2861.0	2862.5	2895.0	2900.0	2906.5				360
2900	2963.0	2964.5	2997.5	3002.2	3009.3				360
3000	3065.0	3066.5	3099.5	3104.4	3112.0				360
3100	3167.0	3168.5	3246.5	3253.5	3274.3				400
3200	3269.0	3270.5	3348.7	3356.1	3377.7				400
3300	3371.0	3372.5	3451.1	3458.5	3481.5				400
3400	3473.0	3474.5	3553.3	3560.9	3589.1				400
3500	3575.0	3576.5	3655.5	3663.3	3692.7				400
3600	3677.0	3678.5	3757.9	3765.5	3796.7				400
3700	3779.0	3780.5	3860.3	3867.9	3900.9				400
3800	3881.0	3882.5	3962.7	3970.3	4004.7				400
3900	3983.0	3984.5	4065.1	4072.5	4106.9				400
4000	4085.0	4086.5	4167.7	4174.7	4213.3				400

Note: For the pressure class PN 1, CL has the following values: 240 mm for DN 300 - DN 500, 290 mm for DN 600 - DN 2500 and 400 mm for DN 2600 - DN 4000.



### 11.1.2 Mechanical Steel Couplings

Usually, mechanical steel couplings (Fig. 27) are used when a GRP pipe is coupled with a pipe made from another material or when work is carried out on an already installed pipe and there isn't enough space to install a Reka coupling. In the latter example, flexible mechanical couplings are used. Their installation requires qualified personnel.

These couplings consist of a steel mantle with an interior sealing rubber sleeve. The mantle can be stainless steel, galvanized steel or epoxy-protected steel.

Mechanical steel couplings are manufactured in three versions: **INSTAL**, **REP** and **TRANS**

- » mechanical steel couplings with a hinge - the couplings don't open, the installation is done at the end of the pipe (ARPOL INSTAL);
- » mechanical steel couplings for repairs, with two hinges which allow the coupling to be open and permit it to pass over the pipe in the repair area (ARPOL REP);
- » mechanical steel coupling for joining different outer diameter pipes (ARPOL TRANS).

For mechanical steel couplings, ROREX collaborates with ARPOL company from Spain.

An alternative is the usage of a special, custom-made steel joining part (Fig. 28). The steel casting is machined on a lathe to have the same external diameter as the GRP pipe. One end of this piece is welded to the steel pipe, and the machined end is connected to a Reka coupling.

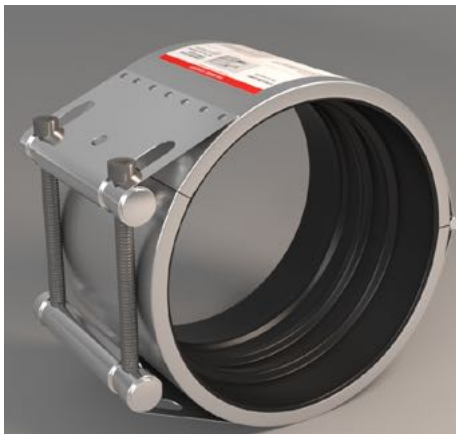
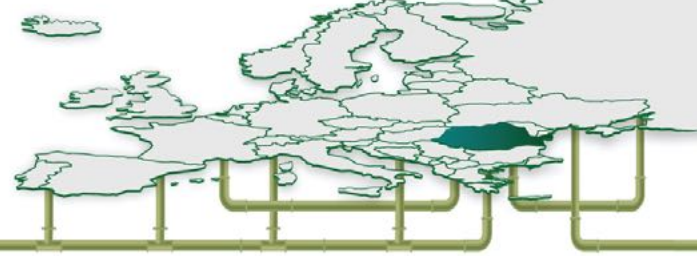

Fig. 27 Metal coupling, lateral view



Fig. 28 Special metal joining part which connects steel pipes to GRP pipes



## 11.2 Restricted Pipe Joining Elements

### 11.2.1 Laminated Joints

Laminated joints (Fig. 29) are manufactured from GRP. The joint component's number of layers, as well as its length, configuration or type, varies according to the diameter and pressure rating of the pipe. They are especially used where pipe joining elements must transmit axial forces from the internal pressure due directional changes, without thrust blocks, or as a repair method. Their installation requires qualified personnel.

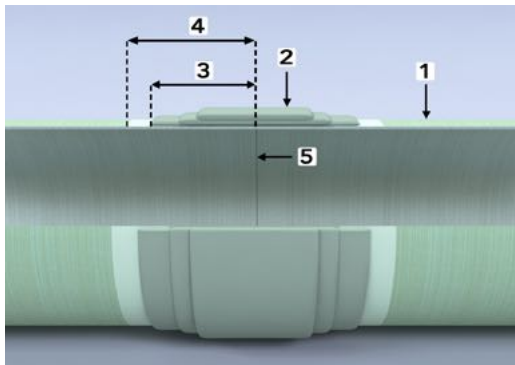

Fig. 29 Laminated joint, where:  
1 - pipe  
2 - lamination  
3 - length of lamination from pipe edge  
4 - length of grinding  
5 - edge of pipe

### 11.2.2 Flanges

The flange (Fig. 30 a) and b)) is a mechanical joining method, used either for joining two pipes together, a pipe with a fitting, or a pipe with a valve. Likewise, it can connect GRP with GRP or GRP with other materials. Flanges are used to create a sealed connection which can be disassembled and reassembled if necessary. The flange disc is a circular surface which has a standard pattern for bolting, based on the pipe outer diameter and the pressure rating.



Fig. 30 a) Flange



Fig. 30 b) Flanges installed on pipes

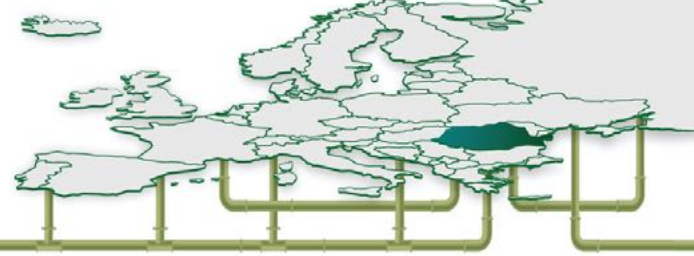

### 11.2.3 Glued couplings (COMBI)

Glued couplings (Fig. 31) are used to connect two biaxial GRP pipes and are equipped with four sealing gaskets. Usually, they are installed on one end of the pipe from the factory. Their length and diameter vary according to the pipe nominal diameter and pressure rating (Table 12 and Table 13). The space between the two sealing gaskets from each end of the pipe is filled with a special resin which bonds the coupling to the pipe.

*Table 12: The length of the glued coupling as a function of the pipe nominal diameter and nominal pressure*

PN (mm)	DN (mm)	CL (mm)
6	1100	566
6	1200	596
10	1100	746
10	1200	776

*Table 13: The external diameter of the glued coupling as a function of the pipe nominal diameter and nominal pressure*

PN (mm)	DN (mm)	DOS max (mm)
6	1100	1190
6	1200	1291
10	1100	1205
10	1200	1306

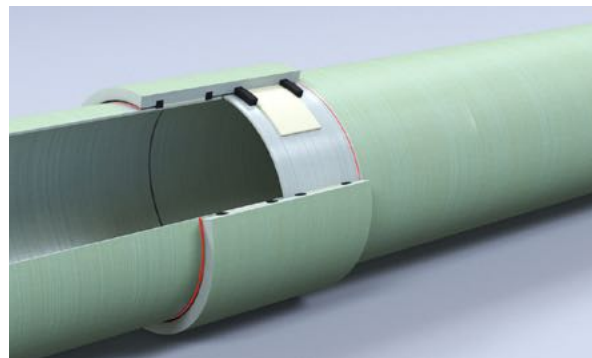

*Fig. 31 Glued coupling (COMBI)*

## 12. Fittings

Fittings complement the straight pipe and must be chemically and mechanically compatible with it. Fittings have different shapes and are designed for three main cases, namely: when a directional change takes place, when a change in the outside diameter of the pipe occurs, or at the junction between two pipes. For example:

- » For directional changes where there are pipes of the same diameter, elbows of different angles can be used;
- » For a reduction in the dimension of the pipe, concentric or eccentric reducers can be used;
- » For a reduction in the dimension of the pipe as well as a directional change, ramifications can be used.

ROREX uses standard manufacturing methods for GRP fittings ([Table 14](#), pg. 54). These can be manufactured in a wide range of standard or non-standard dimensions, for pressure or no-pressure applications depending on the client's needs. Fittings with dimensions up to DN 900 mm can be manufactured mechanically with the continuous filament winding technology. [Fig. 32 - 36](#) (pg. 54) show various types of fittings.

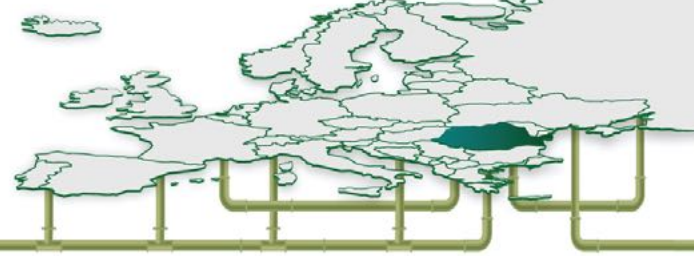

Table 14: ROREX standard fittings

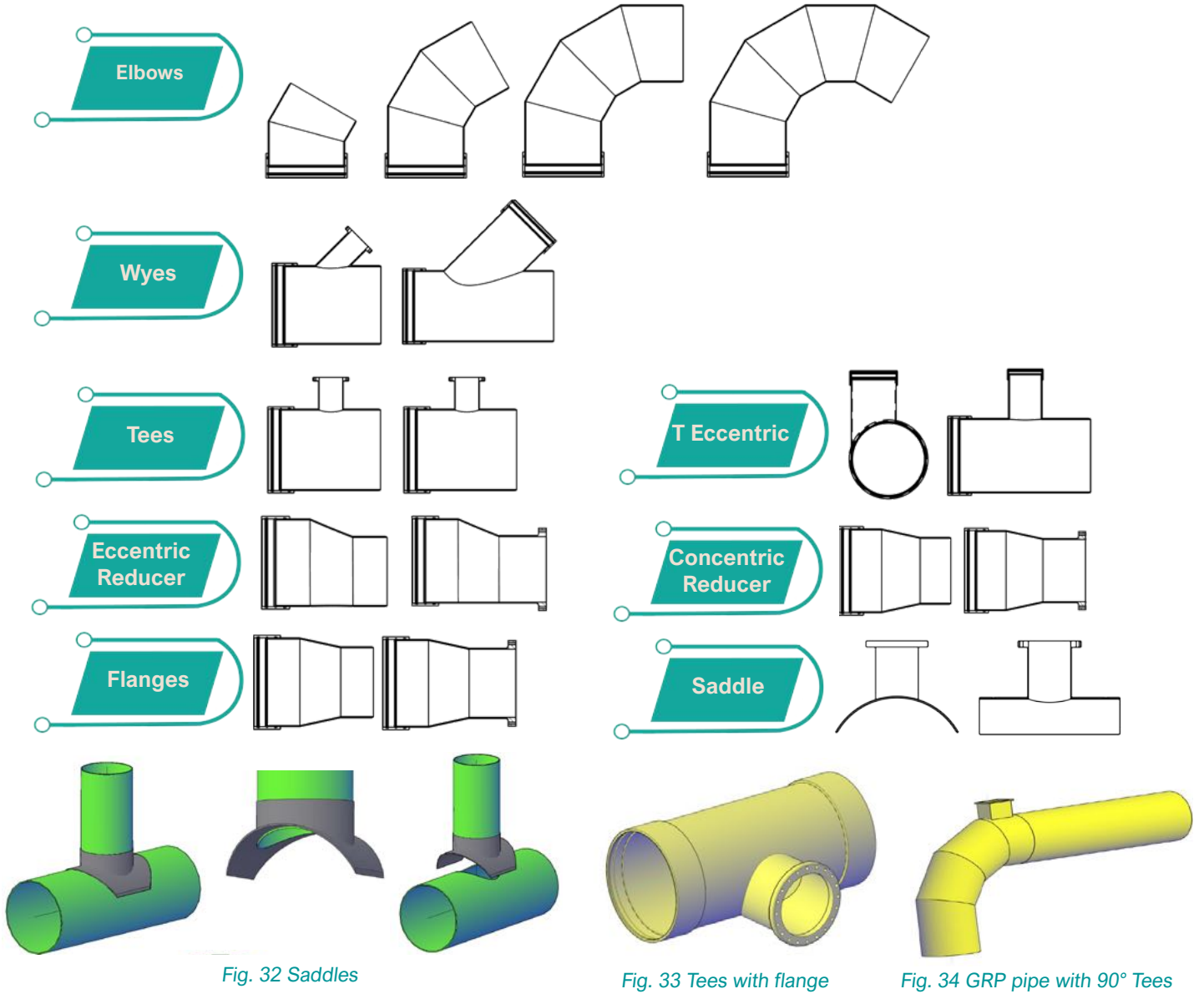

Fig. 32 Saddles

Fig. 33 Tees with flange

Fig. 34 GRP pipe with 90° Tees

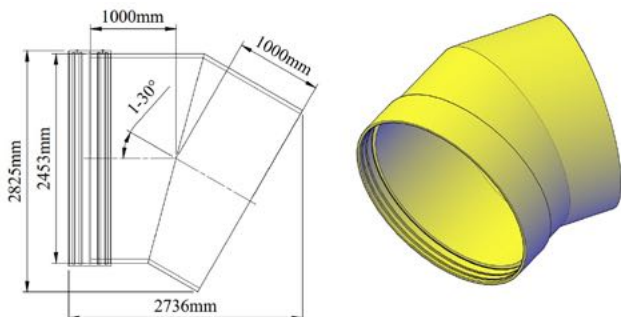

Fig. 35 GRP Tee DN 2400, 1 - 30°

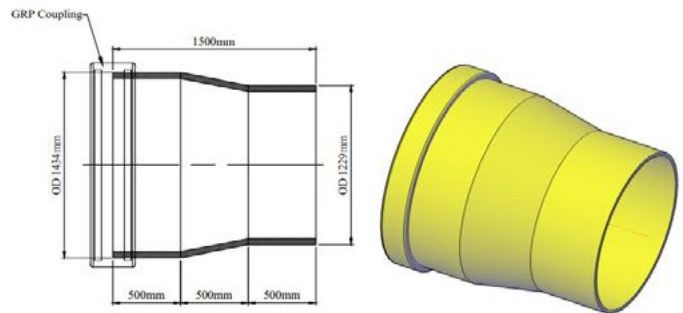
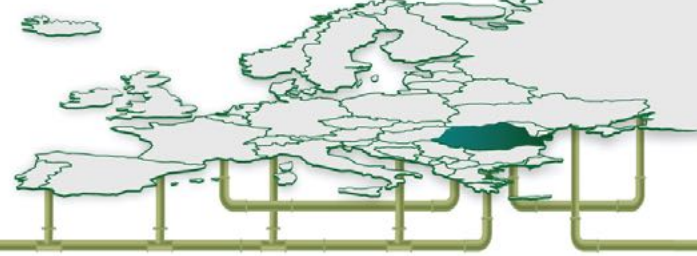

Fig. 36 GRP Reducer DN 1400 - DN 1200





## 13. GRP Pipe Installation

### 13.1 Choosing the Pipe Characteristics According to the Conditions in the Field

The most important parameters that need to be accounted for when installing underground pipes are the stiffness and pressure class. Fig. 37 shows standard underground installations. ROREX GRP pipe corresponding stiffness and pressure classes are mentioned in Table 15. The stiffness class represents the minimum initial stiffness  $EI/D^3$  in  $N/m^2$  (Pa).

Table 15: Pipe stiffness and pressure classes

SN	ISO Pa	ASTM kPa
2500	2500	124
5000	5000	248
10000	10000	496

As mentioned in [chapter 6 \(pg. 25\)](#), the stiffness class is chosen in accordance with three parameters:

1. burial conditions that include natural soil, type of backfill and cover depth;
2. traffic conditions;
3. negative pressure.

The natural soil characteristics are evaluated using the penetration test from the standard ASTM D 1585 - standard for penetration test. The description and properties of non-cohesive and cohesive soils are given in [Table 16](#), pg. 56. The blow count refers to the standard penetration test which classifies the soils according to how compact they are and  $E$  is the soil elasticity modulus.



Fig. 37: Standard underground installation of a uniaxial GRP pipeline DN 2800

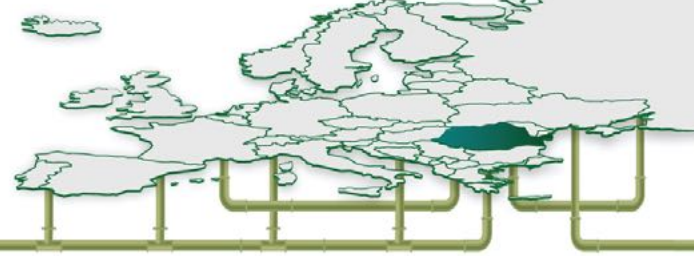

Table 16: Characteristics and engineering properties of non-cohesive and cohesive soils

Native soil group	Blow counts	E'n (MPa)	Description	Friction angle	Description	Unconfined comp. strength (KPa)
1	>15	34,5	compact	33	very stiff	192-384
2	8-15	20,7	slightly compact	30	stiff	96-92
3	4-8	10,3	loose	29	medium	4-96
4	2-4	4,80	very loose	28	soft	24-48
5	1-2	1,40	very loose	24	very soft	12-24
6	0-1	0,34	very, very loose	26	very, very soft	0-12

Table 17 presents the maximum allowable cover depths for a wide range of backfill soil types, three different stiffness classes and six native soil groups. These values are applied for a standard trench and an allowable deflection of 5% (DN 300 mm - 4000 mm) - 4% (DN 100 mm - 250 mm), taking traffic loads into consideration. In most cases, the native soil from the trenches can be used as backfill soil, however, our engineers recommend granular compacted material for this.

Table 17: Native soil groups and backfill soil modulus (MPa) for three stiffness classes

Native soil group	SN 2500						SN 5000						SN 10000						
	1	2	3	4	5	6	1	2	3	4	5	6	1	2	3	4	5	6	
Backfill Soil Modulus(MPa)	20.7	23.0	18.0	11.0	7.0	-	-	23.0	18.0	12.0	7.0	3.0	-	24.0	19.0	12.0	8.0	3.5	-
	13.8	18.0	15.0	10.0	6.0	-	-	18.0	15.0	10.0	6.5	2.4	-	19.0	16.0	11.0	7.0	3.5	-
	10.3	15.0	13.0	9.0	5.5	-	-	15.0	13.0	9.0	6.0	2.4	-	15.0	13.0	10.0	6.5	3.0	-
	6.9	11.0	10.0	7.5	5.0	-	-	11.0	10.0	8.0	5.0	-	-	12.0	10.0	8.5	5.5	3.0	-
	4.8	8.5	7.5	6.0	4.0	-	-	8.5	7.5	6.5	4.5	-	-	9.5	8.5	7.0	5.0	2.5	-
	3.4	6.0	5.5	5.0	3.5	-	-	6.0	6.0	5.0	4.0	-	-	7.0	6.5	5.5	4.5	-	-
	2.1	3.5	3.5	3.5	-	-	-	4.0	4.0	3.5	3.2	-	-	4.5	4.5	4.0	3.5	-	-
	1.4	-	-	-	-	-	-	2.4	2.4	2.2	-	-	-	3.0	3.0	3.0	2.8	-	-

The maximum allowable burial depth is established following a complex statistical calculus, which takes the natural soil's geotechnical and hydrogeological characteristics into consideration.

The second parameter for the pipe stiffness class is the negative pressure. For the cases where this is present, [Tables 18 and 19](#) (pg. 57) indicate the necessary stiffness for different values of the negative pressure and maximum coverage depths for medium native soil conditions and backfill.

The selected stiffness can be higher than the one indicated by the negative pressure values and the burial depth.

In order to ensure a long life and good performance, ROREX GRP pipes require a suitable manipulation and installation. It is necessary to respect the recommended installation conditions, as well as to use a corresponding material for backfill and bedding.

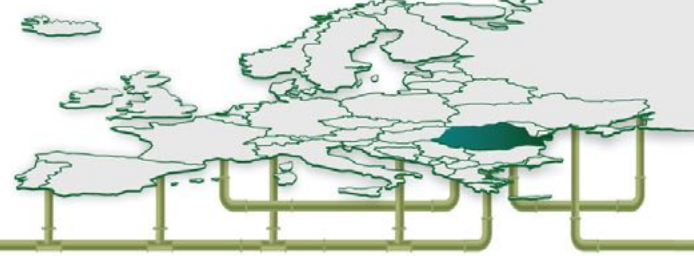

For complete instructions, please consult ROREX Technical Department.

*Table 18: Native soil group 3 ( $E'n=10.3$  MPa).  
backfill type cat. 90% SDP ( $E'b=14$ MPa)  
water table below pipe standard  
trench installation*

*Table 19: For saturated soil conditions*

Vac (bar)	SN 2500	SN 5000	SN 10000	Vac (bar)	SN 2500	SN 5000	SN 10000
-0,25	10,0	10,0	11,0	-0,25	5,5	5,5	6,0
-0,50	8,5	10,0	11,0	-0,50	0,4	5,5	6,0
-0,75	6,5	10,0	11,0	-0,75	1,8	5,5	6,0
-1,00	4,0	10,0	11,0	-1,00	N/A	4,0	6,0

### 13.2 Trench Details

The trench must always be wide enough to permit the access and compaction of the backfill material around the pipe, and a corresponding support must be ensured. The coverage depths presented in chapter [13.3 Types of installation](#) (pg. 59) are based on an accounted trench width of x1.75 nominal diameter. In special cases, widths less than x1.5 nominal diameter can be manufactured. In this case, burial depths can be affected. The bottom of the trench, the bedding, must be made out of a corresponding material which can ensure a uniform and continuous support for the pipe. For example, the width of the bedding should be increased when there are rocks, hard blocks or soft, weak, unstable or very compressible soils. Fig. 38 presents a standard trench, where dimension B, the distance from the pipe to the edge of the trench, must allow for compaction equipment handling and the correct placement of the backfill material under the pipe haunches.

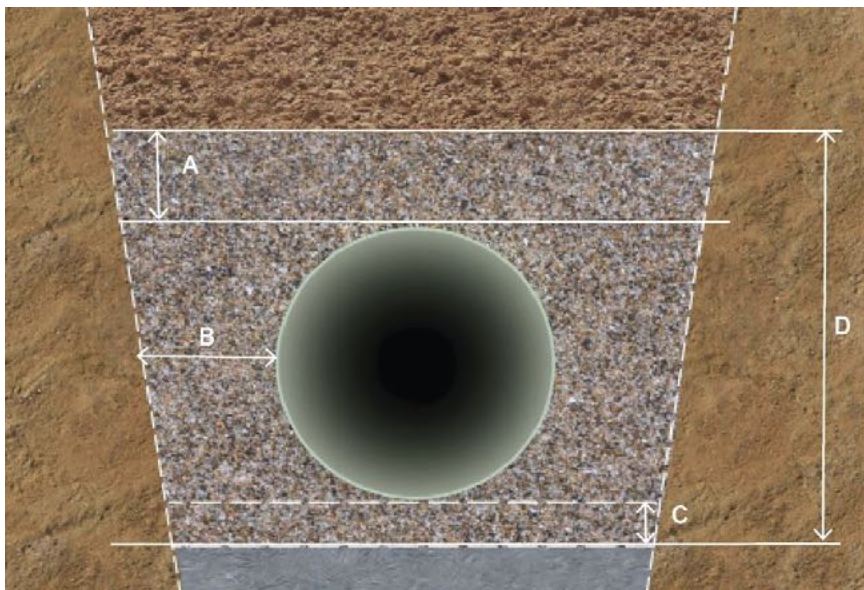

*Fig. 38 A standard trench where:  
A - backfill,  
B - distance from pipe to edge of trench  
C - bedding  
D - pipe zone*

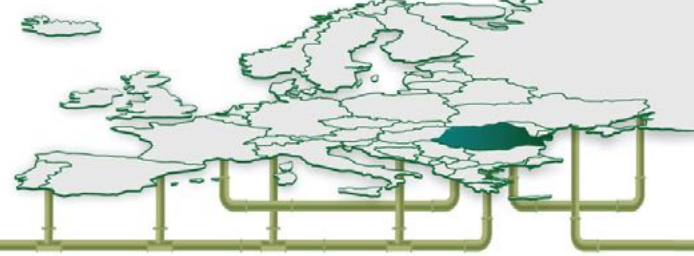

To ensure a satisfactory pipe-soil system, correct backfill material must be used. Most coarse grained soils (as classified by the United Soils Classification System) are acceptable bedding and pipe zone backfill material. Where the use of native soil as backfill is permitted, organic material is not accepted, and the maximum dimension of backfill material is determined by the pipe diameter. Table 20 indicates the acceptable backfill materials.

*Table 20: Backfill materials and their description*

Backfill material	Description	Unified Soil Classification Designation
A	Crushed stone and gravel < 12% fines	GW, GP, GW-GM, GP-GM
B	Gravel with sand, sand < 12% fines	GW-GC, GP-GC, SW, SP, SW-SM, SP-SM, SW-SC, SP-SC
C	Silty gravel and sand, < 12 - 35% fines, LL< 40%	GM, GC, GM-GC, SM, SC, SM-SC
D	Silty, clayey sand, < 12 - 50% fines, LL< 40%	GM, GC, GM-GC, SM, SC, SM-SC
E	Sandy, clayey silt, < 50 - 70% fines, LL< 40%	CL-ML
F	Low plasticity fine-grained soils, LL< 40%	CL-ML

All backfill should be compacted to the required grade when continuous traffic loads are present (Table 21). Minimum cover restrictions can be reduced with special installations such as: concrete encasement, concrete cover slabs, casing etc.

*Table 21: Traffic (wheel) load, force and load type*

Minimum Burial Depth	Force (lbs)	Force (KN)	Load Type
1.0	16000	72	AASHTOH20(C)
1.5	20000	90	BS 153HA(C)
1.0	9000	40	ATV LKW12(C)
1.0	110000	50	ATW SLW(C)
1.5	22000	100	ATW SLW 60(C)
3.0	Railway	-	Cooper E80

Note: Based on a minimum pipe zone backfill modulus of 6.9 MPa

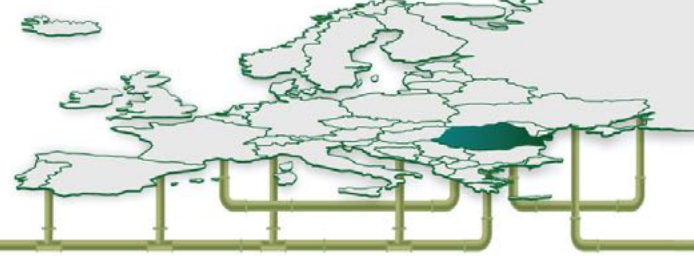

### 13.3 Installation Types

#### Installation Type 1

- » Carefully constructed bedding
- » The pipe backfill zone is up to 300 mm over the pipe crown and is executed using specified backfill material, compacted to the required relative compaction level (Fig. 39)

Note: for non-pressure applications, requirement to compact 300 mm over pipe crown is not applied.

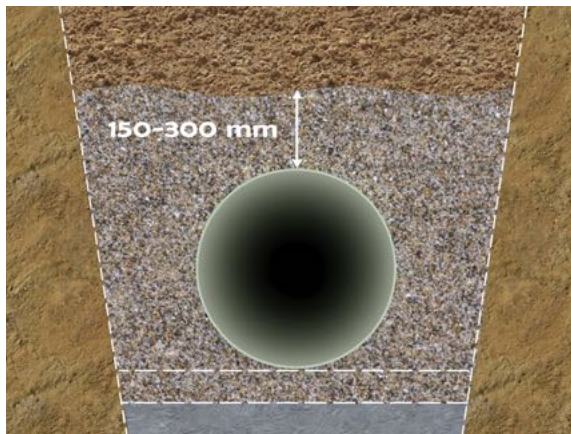

Fig. 39 Installation Type 1

#### Installation Type 2

- » The backfill to 60% pipe diameter is executed using specified backfill material, compacted to the required relative compaction level (Fig. 40)
- » The backfill from 60% diameter to 300 mm over pipe crown is executed with a relative compaction necessary to achieve a minimum soil modulus of 1.4 MPa.

Note: Installation Type 2 is not applicable to small diameter pipes, high traffic load conditions, swampy areas or areas with poor or improper soils.

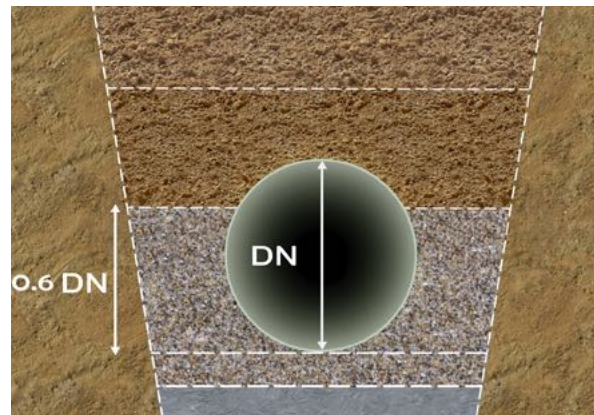
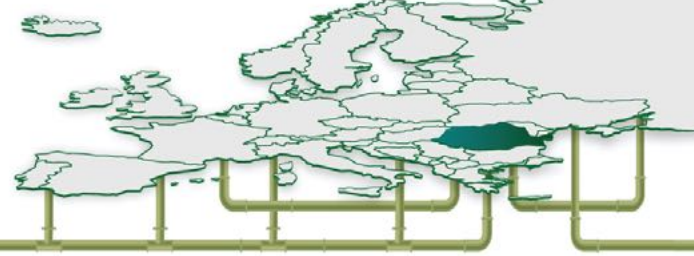

Fig. 40 Installation Type 2

Depending on the conditions in the field, alternative installations can be made, which can, for example, include wider trenches or sheet piles. For using other elements such as soil stabilization, geotextiles etc., please contact ROREX Technical Department.

ROREX GRP pipes can be installed in different conditions, including above-ground applications, in the aquatic environment, trenchless applications or on a slope. These applications require a special initial planning and more care than when installing buried pipes. For more details, please contact ROREX Technical Department.



### 13.4 Special Considerations

- » **Pressure higher than 16 bar** may require deeper burial to prevent the uplift and movement of the pipe. Pipes  $DN \geq 300$  mm should have a min. burial depth of 1.2 m. For pipes with small diameters, the minimum burial depth should be 0.8 m.
- » In the case of **high ground water levels**, a min. earth coverage of  $x0.75$  diameter (min. dry bulk density of  $1900 \text{ kg/m}^3$ ) is required to prevent an empty submerged pipe from floating. Alternatively, the pipe system can be anchored. If anchoring is proposed, restraining straps will be from a flat material - min. 25 mm wide, placed at max. 4 m intervals. Please contact ROREX Technical Department for details on anchoring and minimum cover depths with anchors.

### 13.5 Installed Pipes Deflection

Max. initial deflection	<b>DN &lt; 300</b>	2.5%	<b>DN ≥ 300</b>	3.0%
Max. long term deflection	<b>DN &lt; 300</b>	4,0%	<b>DN ≥ 300</b>	5,0%

The diametrical deflection is typically vertical. The values presented above apply to all stiffness classes. Bulges, flat areas or other abrupt changes of pipe wall curvature are not permitted. Pipe installed outside of these limitations may not perform as intended.

### 13.6 Joint Angular Deflection

Coupling joints are extensively tested and qualified in accordance with EN 1119, ASTM D 4161 și ISO 8639. The pipes can be joined in a straight line, however for the cases where this is not possible an angular deflection occurs ([Fig. 41](#) and [Fig. 42](#) pg. 61). Maximum angular deflection for each coupling joint (measured as change in adjacent pipe center lines) must not exceed the values in [Table 22](#), pag 61.

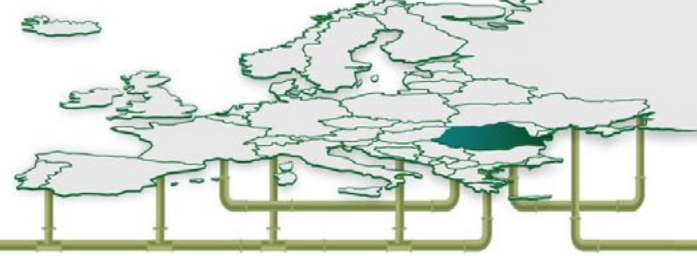

Fig. 41 Joined pipes with angular deflection

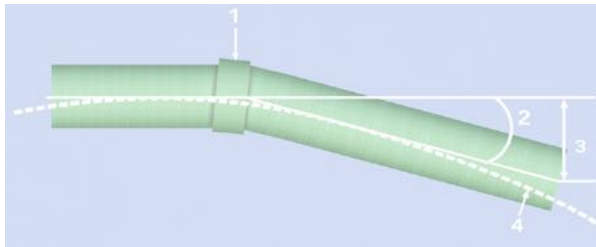

Fig. 42 Angular deflection of the coupling  
where:  
1 - coupling, 2 - deflection angle,  
3 - offset, 4 - radius of curvature

Table 22: Max. allowable deflection angle, max. offset and max. allowable radius of curvature as a function of pipe nominal diameter and pipe length

DN (mm)	Max. angle of deflection (°)	Max. offset (mm)			Max. radius of curvature (m)		
		Pipe Length (m)			Pipe Length (m)		
		3	6	12	3	6	12
DN ≤ 500	3	157	314	628	57	115	229
500 < DN ≤ 900	2	107	209	419	86	172	344
900 < DN ≤ 1800	1	52	105	209	172	344	688
DN < 1800	0.5	26	52	78	344	688	1376

When the GRP pipe system will be operated at pressures exceeding 16 bar, allowable angular joint deflection should be reduced to levels noted in Table 23.

Table 23: Max. allowable angle of deflection as a function of pipe nominal diameter and the pressure at which the pipe system is operated

DN (mm)	Max. angle of deflection (°)		
Pressure (bar)	20	25	32
DN ≤ 500	2.5	2.0	1.5
500 < DN ≤ 900	1.5	1.3	1.0
900 < DN ≤ 1800	0.8	0.5	0.5

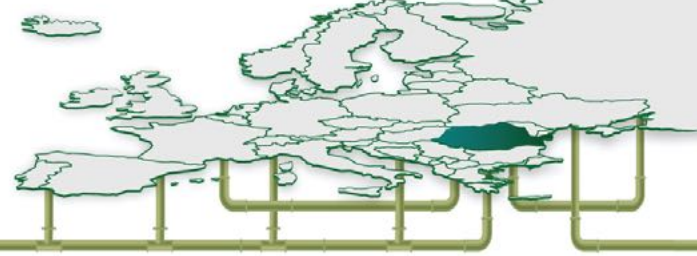

## 14. Special GRP Products

Apart from pipes and fittings, ROREX manufactures a large range of special GRP products, such as:

- » waste water manholes (Fig. 43, [Fig. 44](#) pg. 63 and [Fig. 45](#) pg. 63)
- » waste water pumping station manholes ([Fig. 46](#) pg. 64 and [Fig. 47](#), pg. 64)
- » rainwater retention tanks ([Fig. 48](#), pg. 65)
- » biological modules ([Fig. 49](#), pg. 65)

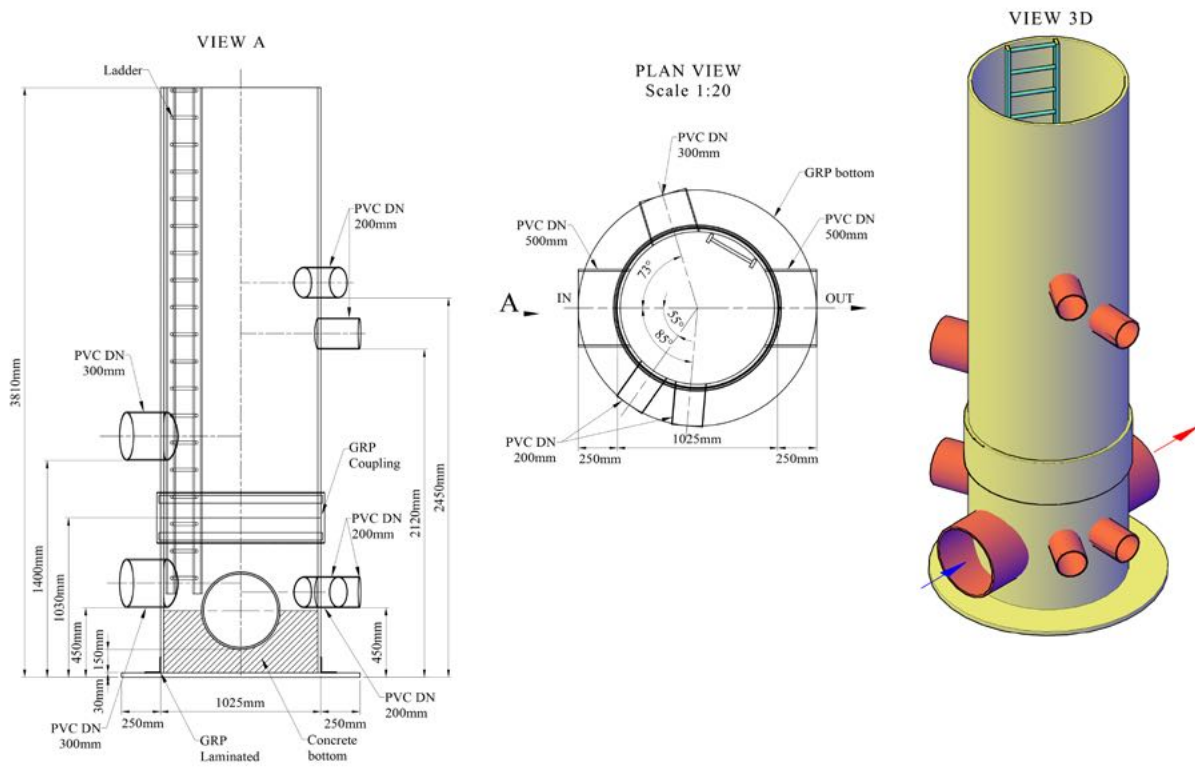

Fig. 43 Manhole DN 1000



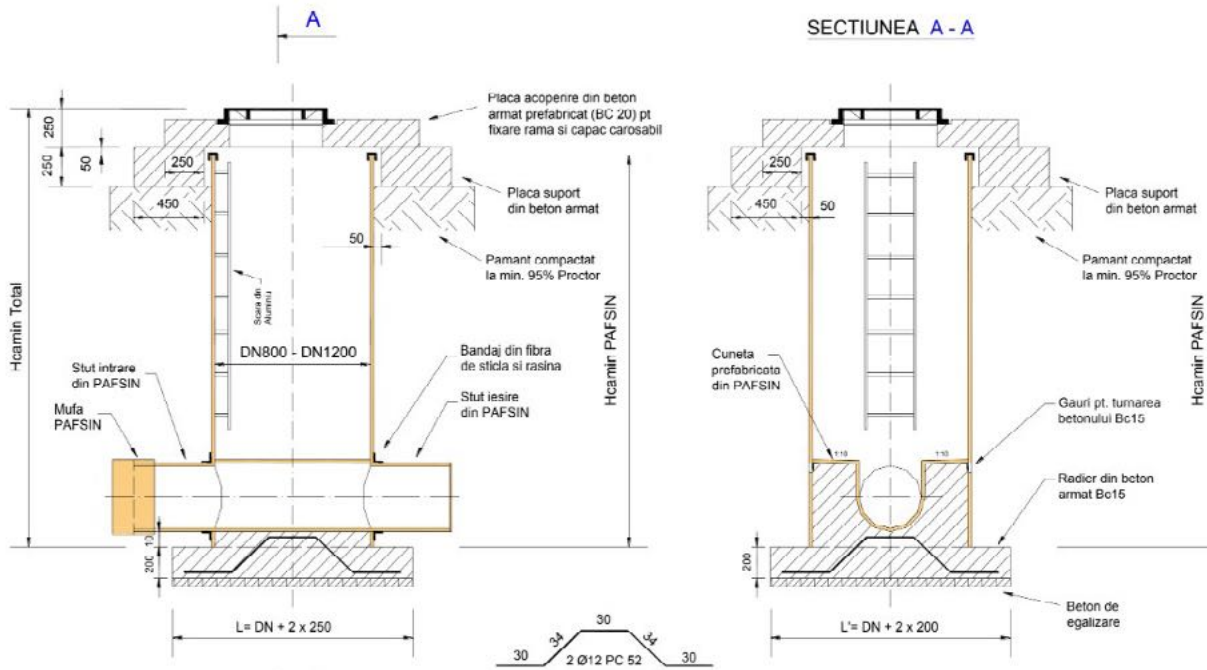
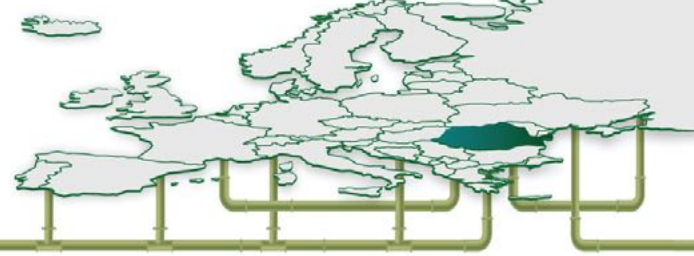

Fig. 44 Straight line manhole

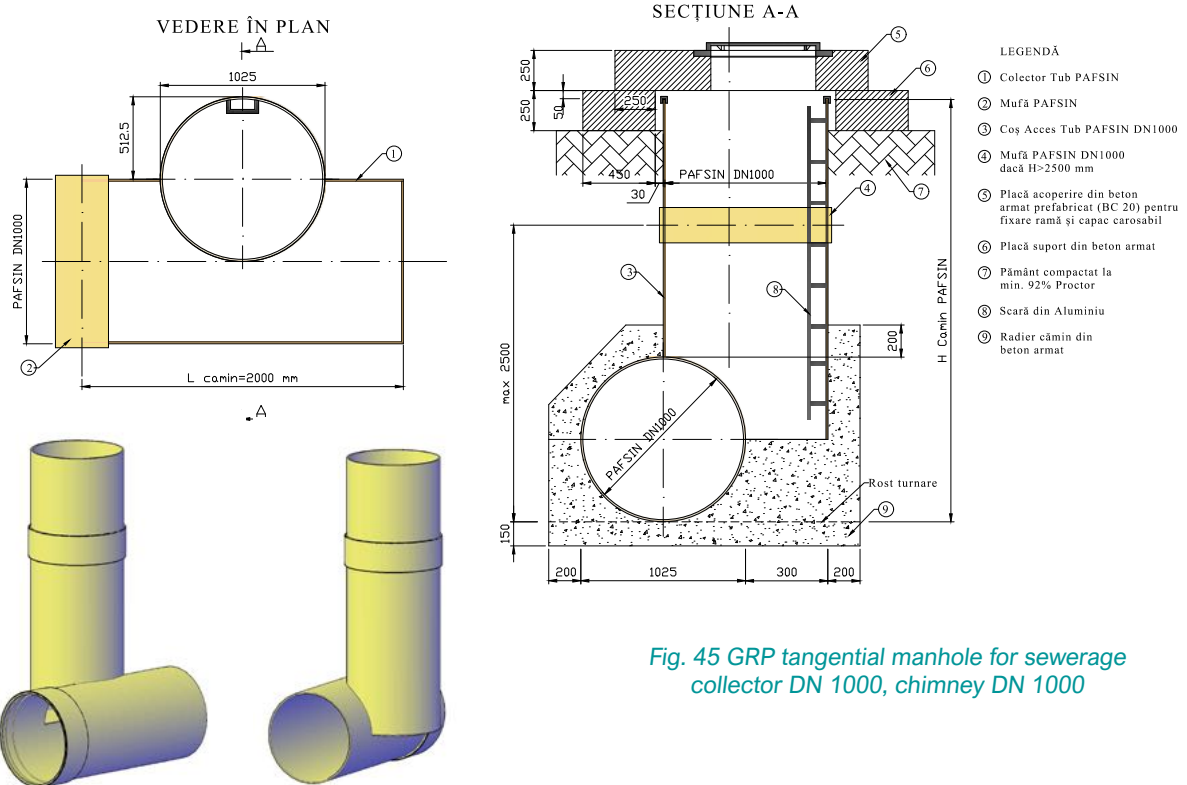

Fig. 45 GRP tangential manhole for sewerage collector DN 1000, chimney DN 1000

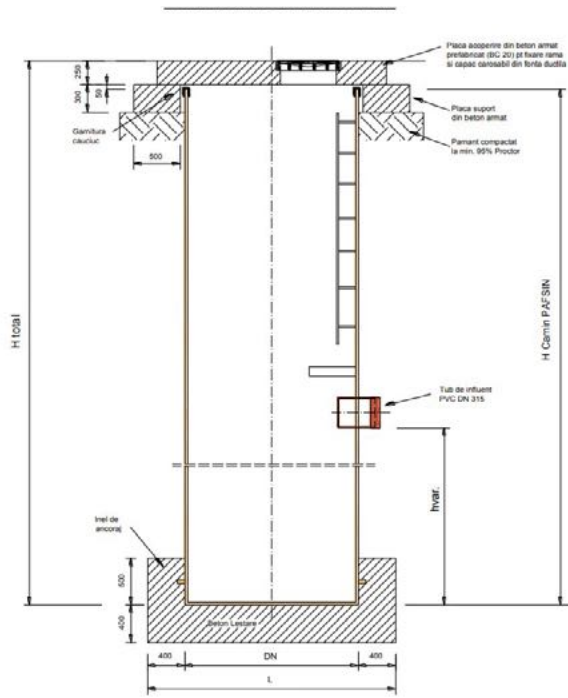
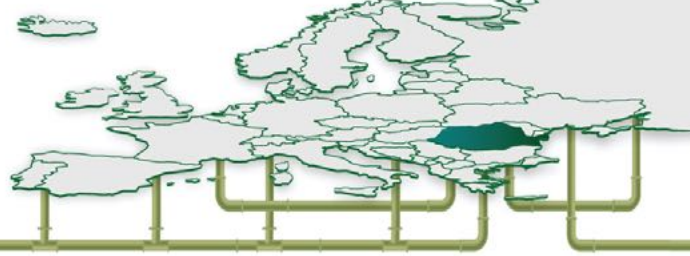

Fig. 46 GRP pumping station manhole

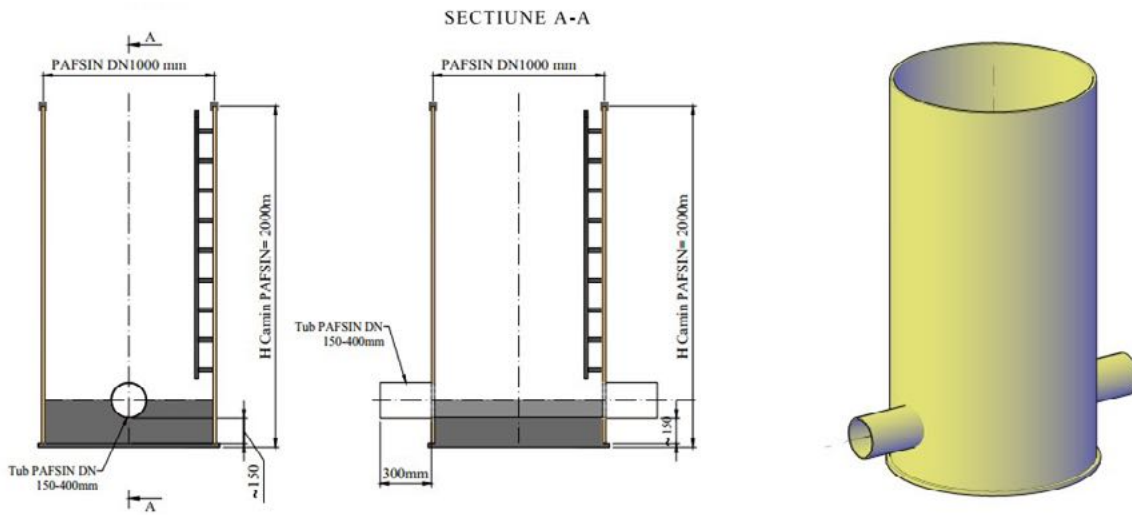

Fig. 47 GRP manhole line chimney

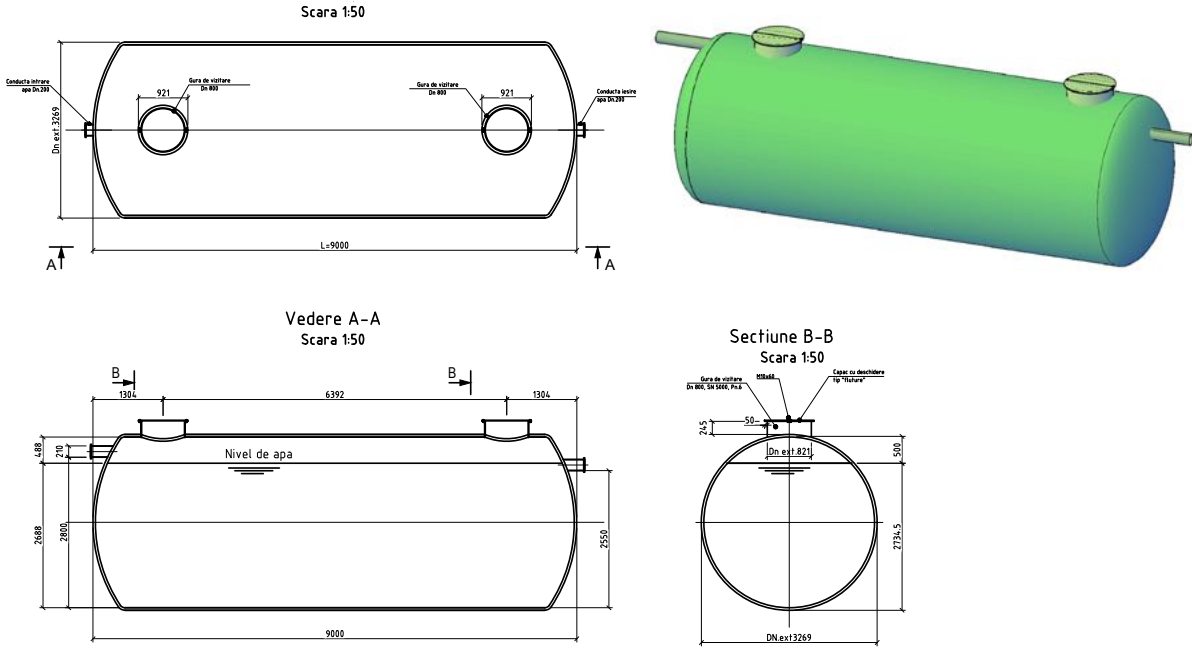
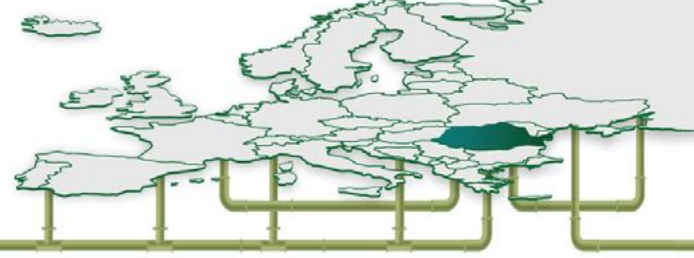
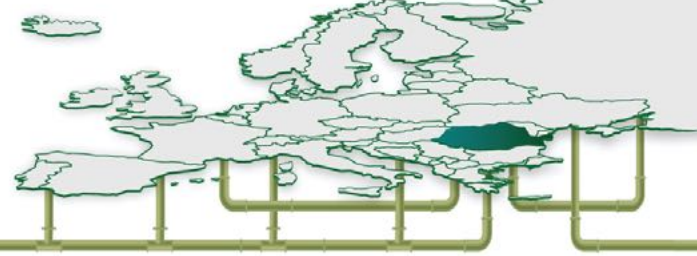

Fig. 48 GRP rainwater retention tank



Fig. 49 GRP biological modules



ROREX also supplies a range of products that are used as an interface between GRP pipes and other components made of different materials. For example:

- » Sanded couplings (Fig. 50)



*Fig. 50 Sanded couplings*



**DIN EN ISO 9001:2015**

**DIN EN ISO 14001:2015**

**DIN EN ISO 45001:2018**





## ROREX PIPE SRL

33 Aviației Street, Buftea City,  
 Ilfov County, Romania  
 Tel. no.: +40 723 277 877  
 Fax: +40 376 206 509  
 office@rorexpipeline.com  
 www.rorexpipeline.com